

INSTRUCTION BOOK

OIL-INJECTED ROTARY SCREW COMPRESSORS

GA 7 VSD+, GA 11 VSD+, GA 15 VSD+



Atlas Copco

Oil-injected rotary screw compressors

GA 7 VSD+, GA 11 VSD+, GA 15 VSD+

From following serial No. onwards: WUX 340 000

Instruction book

Original instructions

COPYRIGHT NOTICE

Any unauthorized use or copying of the contents or any part thereof is prohibited.

This applies in particular to trademarks, model denominations, part numbers and drawings.

This instruction book is valid for CE as well as non-CE labelled machines. It meets the requirements for instructions specified by the applicable European directives as identified in the Declaration of Conformity.

2019 - 11

No. 2920 7120 83

www.atlascopco.com



Table of contents

1	Safety precautions.....	5
1.1	SAFETY ICONS.....	5
1.2	SAFETY PRECAUTIONS, GENERAL.....	5
1.3	SAFETY PRECAUTIONS DURING INSTALLATION.....	6
1.4	SAFETY PRECAUTIONS DURING OPERATION.....	7
1.5	SAFETY PRECAUTIONS DURING MAINTENANCE OR REPAIR.....	8
1.6	DISMANTLING AND DISPOSAL.....	10
2	General description.....	11
2.1	INTRODUCTION.....	11
2.2	FLOW DIAGRAM.....	15
2.3	CONDENSATE SYSTEM.....	17
2.4	REGULATING SYSTEM.....	19
2.5	ELECTRICAL SYSTEM.....	20
2.6	AIR DRYER.....	21
3	Elektronikon™ Touch controller.....	23
3.1	CONTROLLER.....	23
3.2	CONTROL PANEL.....	25
3.3	ICONS USED.....	26
3.4	MAIN SCREEN.....	30
3.5	QUICK ACCESS SCREEN.....	31
3.6	MENU SCREEN.....	32
3.7	DATA MENU.....	34
3.8	SERVICE MENU.....	36
3.9	WEEK TIMER MENU.....	38
3.10	EVENT HISTORY MENU.....	39
3.11	MACHINE SETTINGS MENU.....	40



3.12	CONTROLLER SETTINGS MENU.....	43
3.13	ACCESS LEVEL.....	46
4	Installation.....	48
4.1	DIMENSION DRAWINGS.....	48
4.2	INSTALLATION PROPOSAL.....	51
4.3	ELECTRICAL CONNECTIONS.....	54
4.4	PICTOGRAPHS.....	56
5	Operating instructions.....	57
6	Maintenance.....	63
6.1	PREVENTIVE MAINTENANCE SCHEDULE.....	63
6.2	OIL SPECIFICATIONS.....	67
6.3	DRIVE MOTOR	68
6.4	AIR FILTER.....	68
6.5	OIL, OIL FILTER AND OIL SEPARATOR CHANGE.....	69
6.6	COOLERS.....	71
6.7	DRYER MAINTENANCE INSTRUCTIONS.....	72
6.8	SAFETY VALVES.....	73
6.9	SERVICE KITS.....	74
6.10	STORAGE AFTER INSTALLATION.....	74
7	Problem solving.....	75
8	Technical data.....	80
8.1	READINGS ON DISPLAY.....	80
8.2	ELECTRIC CABLE SIZE AND FUSES.....	81
8.3	REFERENCE CONDITIONS AND LIMITATIONS.....	85
8.4	COMPRESSOR DATA.....	85
8.5	TECHNICAL DATA CONTROLLER.....	88

9	Instructions for use.....	89
10	Guidelines for inspection.....	90
11	Declaration of conformity.....	91

1 Safety precautions

1.1 Safety icons

Explanation

	Danger to life
	Warning
	Important note

1.2 Safety precautions, general

General precautions

1. The operator must employ safe working practices and observe all related work safety requirements and regulations.
2. If any of the following statements does not comply with the applicable legislation, the stricter of the two shall apply.
3. Installation, operation, maintenance and repair work must only be performed by authorized, trained, specialized personnel.
4. The compressor is not considered capable of producing air of breathing quality. For air of breathing quality, the compressed air must be adequately purified according to the applicable legislation and standards.
5. Before any maintenance, repair work, adjustment or any other non-routine checks, stop the compressor, press the emergency stop button, switch off the voltage and depressurize the compressor. In addition, the power isolating switch must be opened and locked.
The units are powered by a frequency converter, wait 10 minutes before starting any electrical repair.

	In a domestic environment, this product may cause radio interference in which case supplementary mitigation measures are required.
---	--

	If the machine is equipped with an automatic restart after voltage failure function and if this function is active, be aware that the machine will restart automatically when the power is restored if it was running when the power was interrupted!
---	---

6. Never play with compressed air. Do not apply the air to your skin or direct an air stream at people. Never use the air to clean dirt from your clothes. When using the air to clean equipment, do so with extreme caution and wear eye protection.
7. The owner is responsible for maintaining the unit in safe operating condition. Parts and accessories shall be replaced if unsuitable for safe operation.
8. It is not allowed to walk or stand on the unit or on its components.

1.3 Safety precautions during installation



All responsibility for any damage or injury resulting from neglecting these precautions, or non observance of the normal caution and care required for installation, operation, maintenance and repair, even if not expressly stated, will be disclaimed by the manufacturer.

Precautions during installation

1. The machine must only be lifted using suitable equipment in accordance with the applicable safety regulations. Loose or pivoting parts must be securely fastened before lifting. It is strictly forbidden to dwell or stay in the risk zone under a lifted load. Lifting acceleration and deceleration must be kept within safe limits. Wear a safety helmet when working in the area of overhead or lifting equipment.
2. The unit is designed for indoor use. If the unit is installed outdoors, special precautions must be taken; consult your supplier.
3. In case the device is a compressor, place the machine where the ambient air is as cool and clean as possible. If necessary, install a suction duct. Never obstruct the air inlet. Care must be taken to minimize the entry of moisture at the inlet air.
4. Any blanking flanges, plugs, caps and desiccant bags must be removed before connecting the pipes.
5. Air hoses must be of correct size and suitable for the working pressure. Never use frayed, damaged or worn hoses. Distribution pipes and connections must be of the correct size and suitable for the working pressure.
6. In case the device is a compressor, the aspirated air must be free of flammable fumes, vapors and particles, e.g. paint solvents, that can lead to internal fire or explosion.
7. In case the device is a compressor, arrange the air intake so that loose clothing worn by people cannot be drawn in.
8. Ensure that the discharge pipe from the compressor to the aftercooler or air net is free to expand under heat and that it is not in contact with or close to flammable materials.
9. No external force may be exerted on the air outlet valve; the connected pipe must be free of strain.
10. If remote control is installed, the machine must bear a clear sign stating: DANGER: This machine is remotely controlled and may start without warning. The operator has to make sure that the machine is stopped and depressurized and that the electrical isolating switch is open, locked and labelled with a temporary warning before any maintenance or repair. As a further safeguard, persons switching on or off remotely controlled machines shall take adequate precautions to ensure that there is no one checking or working on the machine. To this end, a suitable notice shall be affixed to the start equipment.
11. Air-cooled machines must be installed in such a way that an adequate flow of cooling air is available and that the exhausted air does not recirculate to the compressor air inlet or cooling air inlet.
12. The electrical connections must correspond to the applicable codes. The machines must be earthed and protected against short circuits by fuses in all phases. A lockable power isolating switch must be installed near the compressor.
13. On machines with automatic start/stop system or if the automatic restart function after voltage failure is activated, a sign stating "This machine may start without warning" must be affixed near the instrument panel.

14. In multiple compressor systems, manual valves must be installed to isolate each compressor. Non-return valves (check valves) must not be relied upon for isolating pressure systems.
15. Never remove or tamper with the safety devices, guards or insulation fitted on the machine. Every pressure vessel or auxiliary installed outside the machine to contain air above atmospheric pressure must be protected by a pressure relieving device or devices as required.
16. Piping or other parts with a temperature in excess of 70°C (158°F) and which may be accidentally touched by personnel in normal operation must be guarded or insulated. Other high temperature piping must be clearly marked.
17. For water-cooled machines, the cooling water system installed outside the machine has to be protected by a safety device with set pressure according to the maximum cooling water inlet pressure.
18. If the ground is not level or can be subject to variable inclination, consult the manufacturer.
19. If the device is a dryer and no free extinguishing system is present in the air net close to the dryer, safety valves must be installed in the vessels of the dryer.



Also consult following safety precautions: [Safety precautions during operation](#) and [Safety precautions during maintenance](#).
 These precautions apply to machinery processing or consuming air or inert gas. Processing of any other gas requires additional safety precautions typical to the application which are not included herein.
 Some precautions are general and cover several machine types and equipment; hence some statements may not apply to your machine.

1.4 Safety precautions during operation



All responsibility for any damage or injury resulting from neglecting these precautions, or non observance of the normal caution and care required for installation, operation, maintenance and repair, even if not expressly stated, will be disclaimed by the manufacturer.

Precautions during operation

1. Never touch any piping or components of the machine during operation.
2. Use only the correct type and size of hose end fittings and connections. When blowing through a hose or air line, ensure that the open end is held securely. A free end will whip and may cause injury. Make sure that a hose is fully depressurized before disconnecting it.
3. Persons switching on remotely controlled machines shall take adequate precautions to ensure that there is no one checking or working on the machine. To this end, a suitable notice shall be affixed to the remote start equipment.
4. Never operate the machine when there is a possibility of taking in flammable or toxic fumes, vapors or particles.
5. Never operate the machine below or in excess of its limit ratings.
6. Keep all bodywork doors shut during operation. The doors may be opened for short periods only, e.g. to carry out routine checks. Wear ear protectors when opening a door.
 On machines without bodywork, wear ear protection in the vicinity of the machine.
7. People staying in environments or rooms where the sound pressure level reaches or exceeds 80 dB(A) shall wear ear protectors.
8. Periodically check that:

- All guards are in place and securely fastened
 - All hoses and/or pipes inside the machine are in good condition, secure and not rubbing
 - No leaks occur
 - All fasteners are tight
 - All electrical leads are secure and in good order
 - Safety valves and other pressure relief devices are not obstructed by dirt or paint
 - Air outlet valve and air net, i.e. pipes, couplings, manifolds, valves, hoses, etc. are in good repair, free of wear or abuse
 - Air cooling filters of the electrical cabinet are not clogged
9. If warm cooling air from compressors is used in air heating systems, e.g. to warm up a workroom, take precautions against air pollution and possible contamination of the breathing air.
 10. On water-cooled compressors using open circuit cooling towers, protective measures must be taken to avoid the growth of harmful bacteria such as Legionella pneumophila bacteria.
 11. Do not remove any of, or tamper with, the sound-damping material.
 12. Never remove or tamper with the safety devices, guards or insulations fitted on the machine. Every pressure vessel or auxiliary installed outside the machine to contain air above atmospheric pressure shall be protected by a pressure relieving device or devices as required.
 13. Yearly inspect the air receiver. Minimum wall thickness as specified in the instruction book must be respected. Local regulations remain applicable if they are more strict.



Also consult following safety precautions: [Safety precautions during installation](#) and [Safety precautions during maintenance](#).
 These precautions apply to machinery processing or consuming air or inert gas. Processing of any other gas requires additional safety precautions typical to the application which are not included herein.
 Some precautions are general and cover several machine types and equipment; hence some statements may not apply to your machine.

1.5 Safety precautions during maintenance or repair



All responsibility for any damage or injury resulting from neglecting these precautions, or non observance of the normal caution and care required for installation, operation, maintenance and repair, even if not expressly stated, will be disclaimed by the manufacturer.

Precautions during maintenance or repair

1. Always use the correct safety equipment (such as safety glasses, gloves, safety shoes, etc.).
2. Use only the correct tools for maintenance and repair work.
3. Use only genuine spare parts for maintenance or repair. The manufacturer will disclaim all damage or injuries caused by the use of non-genuine spare parts.
4. All maintenance work shall only be undertaken when the machine has cooled down.
5. A warning sign bearing a legend such as "Work in progress; do not start" shall be attached to the starting equipment.

6. Persons switching on remotely controlled machines shall take adequate precautions to ensure that there is no one checking or working on the machine. To this end, a suitable notice shall be affixed to the remote start equipment.
7. Close the compressor air outlet valve and depressurize the compressor before connecting or disconnecting a pipe.
8. Before removing any pressurized component, effectively isolate the machine from all sources of pressure and relieve the entire system of pressure.
9. Never use flammable solvents or carbon tetrachloride for cleaning parts. Take safety precautions against toxic vapors of cleaning liquids.
10. Scrupulously observe cleanliness during maintenance and repair. Keep dirt away by covering the parts and exposed openings with a clean cloth, paper or tape.
11. Never weld or perform any operation involving heat near the oil system. Oil tanks must be completely purged, e.g. by steam cleaning, before carrying out such operations. Never weld on, or in any way modify, pressure vessels.
12. Whenever there is an indication or any suspicion that an internal part of a machine is overheated, the machine shall be stopped but no inspection covers shall be opened before sufficient cooling time has elapsed; this to avoid the risk of spontaneous ignition of the oil vapor when air is admitted.
13. Never use a light source with open flame for inspecting the interior of a machine, pressure vessel, etc.
14. Make sure that no tools, loose parts or rags are left in or on the machine.
15. All regulating and safety devices shall be maintained with due care to ensure that they function properly. They may not be put out of action.
16. Before clearing the machine for use after maintenance or overhaul, check that operating pressures, temperatures and time settings are correct. Check that all control and shut-down devices are fitted and that they function correctly. If removed, check that the coupling guard of the compressor drive shaft has been reinstalled.
17. Every time the separator element is renewed, examine the discharge pipe and the inside of the oil separator vessel for carbon deposits; if excessive, the deposits should be removed.
18. Protect the motor, air filter, electrical and regulating components, etc. to prevent moisture from entering them, e.g. when steam cleaning.
19. Make sure that all sound-damping material and vibration dampers, e.g. damping material on the bodywork and in the air inlet and outlet systems of the compressor, is in good condition. If damaged, replace it by genuine material from the manufacturer to prevent the sound pressure level from increasing.
20. Never use caustic solvents which can damage materials of the air net, e.g. polycarbonate bowls.
21. **Only if applicable, the following safety precautions are stressed when handling refrigerant:**
 - Never inhale refrigerant vapors. Check that the working area is adequately ventilated; if required, use breathing protection.
 - Always wear special gloves. In case of refrigerant contact with the skin, rinse the skin with water. If liquid refrigerant contacts the skin through clothing, never tear off or remove the latter; flush abundantly with fresh water over the clothing until all refrigerant is flushed away; then seek medical first aid.



Also consult following safety precautions: [Safety precautions during installation](#) and [Safety precautions during operation](#).
These precautions apply to machinery processing or consuming air or inert gas. Processing of any other gas requires additional safety precautions typical to the application which are not included herein.
Some precautions are general and cover several machine types and equipment; hence some statements may not apply to your machine.

1.6 Dismantling and disposal

Dismantling

Once the end of life of the machine is reached, please follow next steps:

1. Stop the machine.
2. Check all safety precautions mentioned in the previous chapters to secure safe handling (e.g. LOTO, cool-down, depressurize, discharge, ...).
3. Separate the harmful from the safe components (e.g. drain oil from oil containing parts).
4. Refer to the disposal topic mentioned below.

Disposal of electrical and electronic appliances (WEEE)

This equipment falls under the provisions of the European Directive 2012/19/EU on waste electrical and electronic appliances (WEEE) and may not be disposed as unsorted waste.



The equipment is labelled in accordance with the European Directive 2012/19/EU with the crossed-out wheeled bin symbol.

At the end of life-time of the electric and electronic equipment (EEE) it must be taken to separate collection.

For more information check with your local waste authority, customer center or distributor.

Disposal of other used material

Used filters or any other used material (e.g. desiccant, lubricants, cleaning rags, machine parts, etc.) must be disposed of in an environmentally friendly and safe manner, and in line with the local recommendations and environmental legislation.

2 General description

2.1 Introduction

Introduction

GA 7 VSD+ up to GA 15 VSD+ are single-stage, oil-injected screw compressors driven by an interior permanent magnet (English: Interior Permanent Magnet (IPM)) motor.

The compressors are controlled by the Atlas Copco Elektronikon™ Touch controller (ER).

The controller is fitted to the front panel. An electric cabinet (1) comprising fuses, transformers, relays, etc. is located behind this panel.

The compressors use VSD (English: Variable Speed Drive) technology. This means: automatic adjustment of the motor speed, depending on the compressed air demand.

The compressors are air-cooled and are enclosed in a sound-insulated bodywork.

GA Workplace

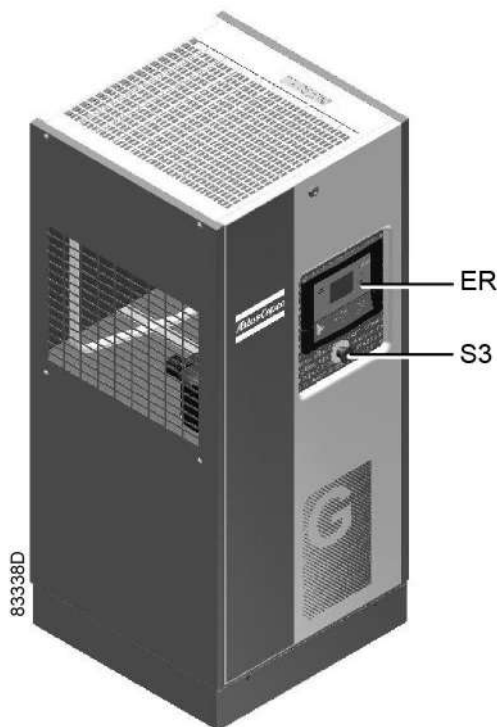

Front view, GA VSD+ Workplace

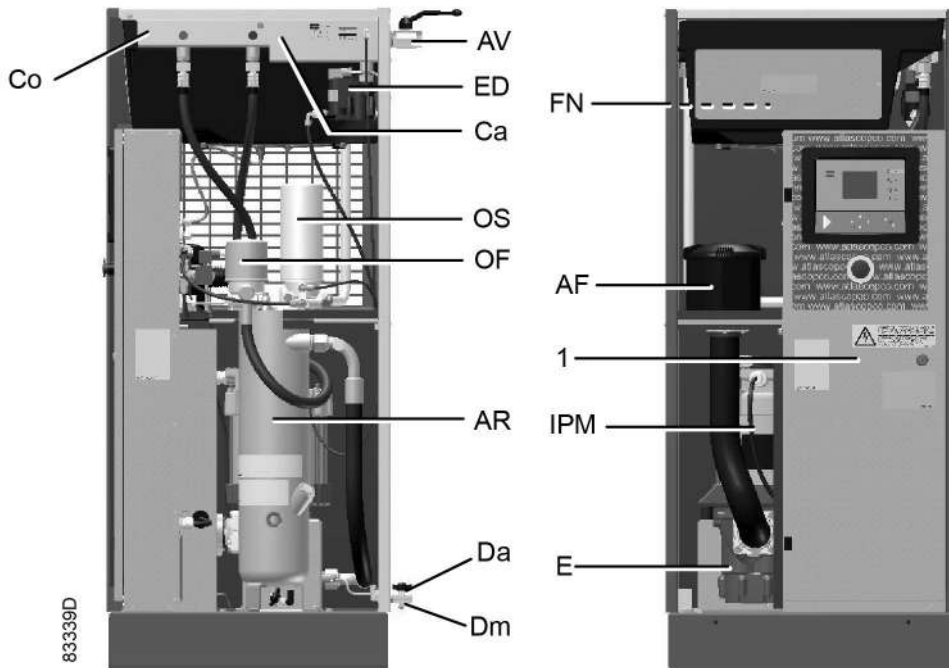

Open side view, GA VSD+ Workplace

GA Workplace Full-Feature

The Workplace Full-Feature compressors have an air dryer which is integrated in the sound-insulated bodywork. The dryer removes condensate from the compressed air by cooling the air to near freezing point.

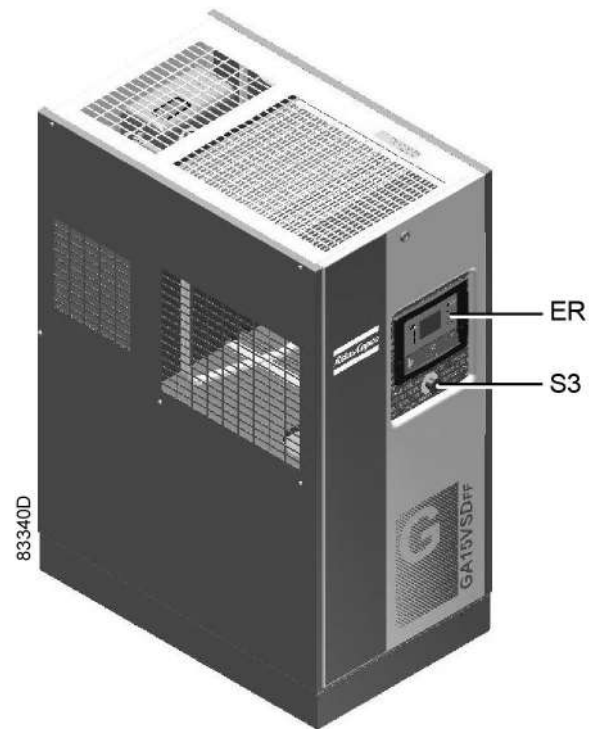

Front view, GA VSD+ Workplace Full-Feature

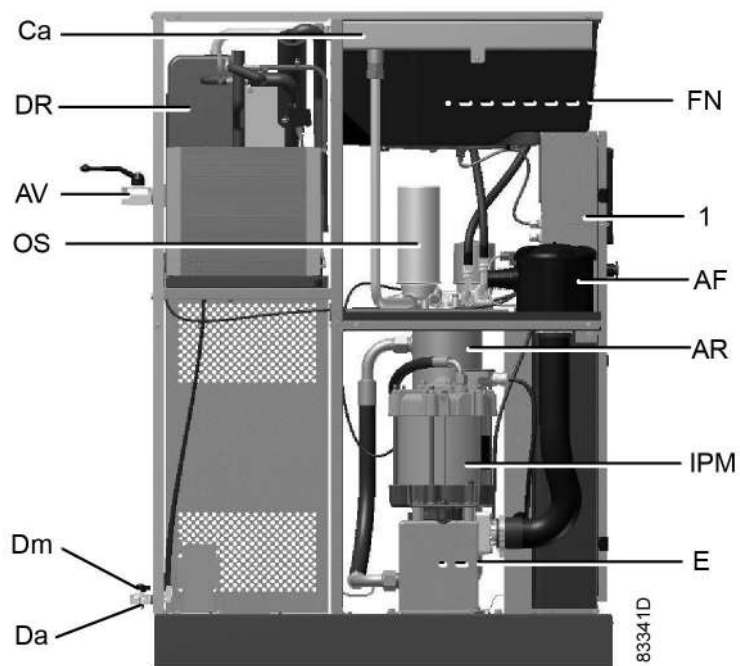

Open side view, GA VSD+ Workplace Full-Feature

Reference	Name
AF	Air filter
AR	Air receiver

Reference	Name
AV	Air outlet
Ca	Air cooler
Co	Oil cooler
Da	Automatic condensate outlet
Dm	Manual condensate outlet
DR	Refrigerant dryer
E	Compressor element
ED	Electronic water drain
ER	Elektronikon™ Touch controller
FN	Cooling fan
IPM	Drive motor
OF	Oil filter
OS	Oil separator
S3	Emergency stop button
1	Electric cabinet

2.2 Flow diagram

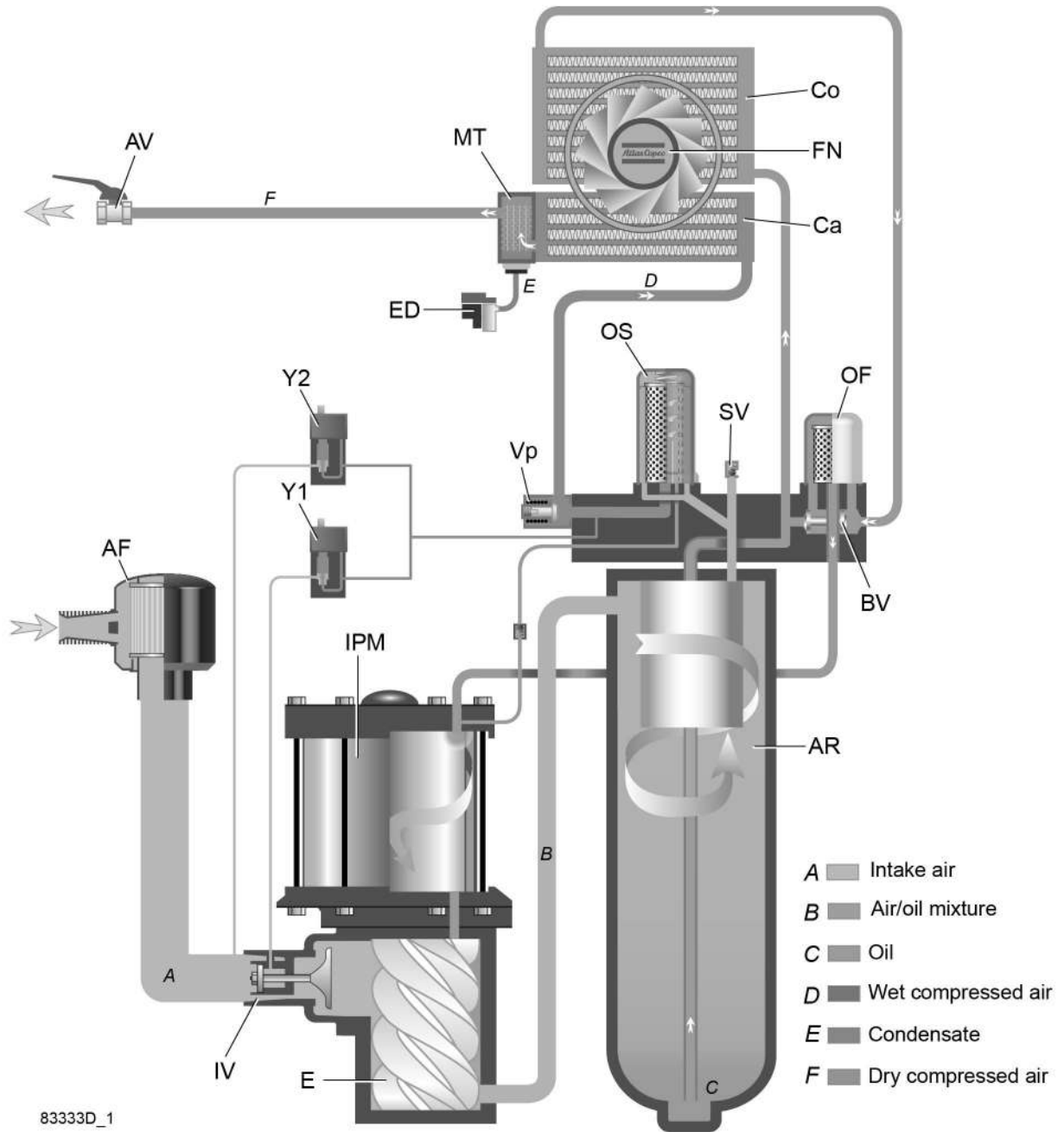

GA 7 VSD+ up to GA 15 VSD+ Workplace

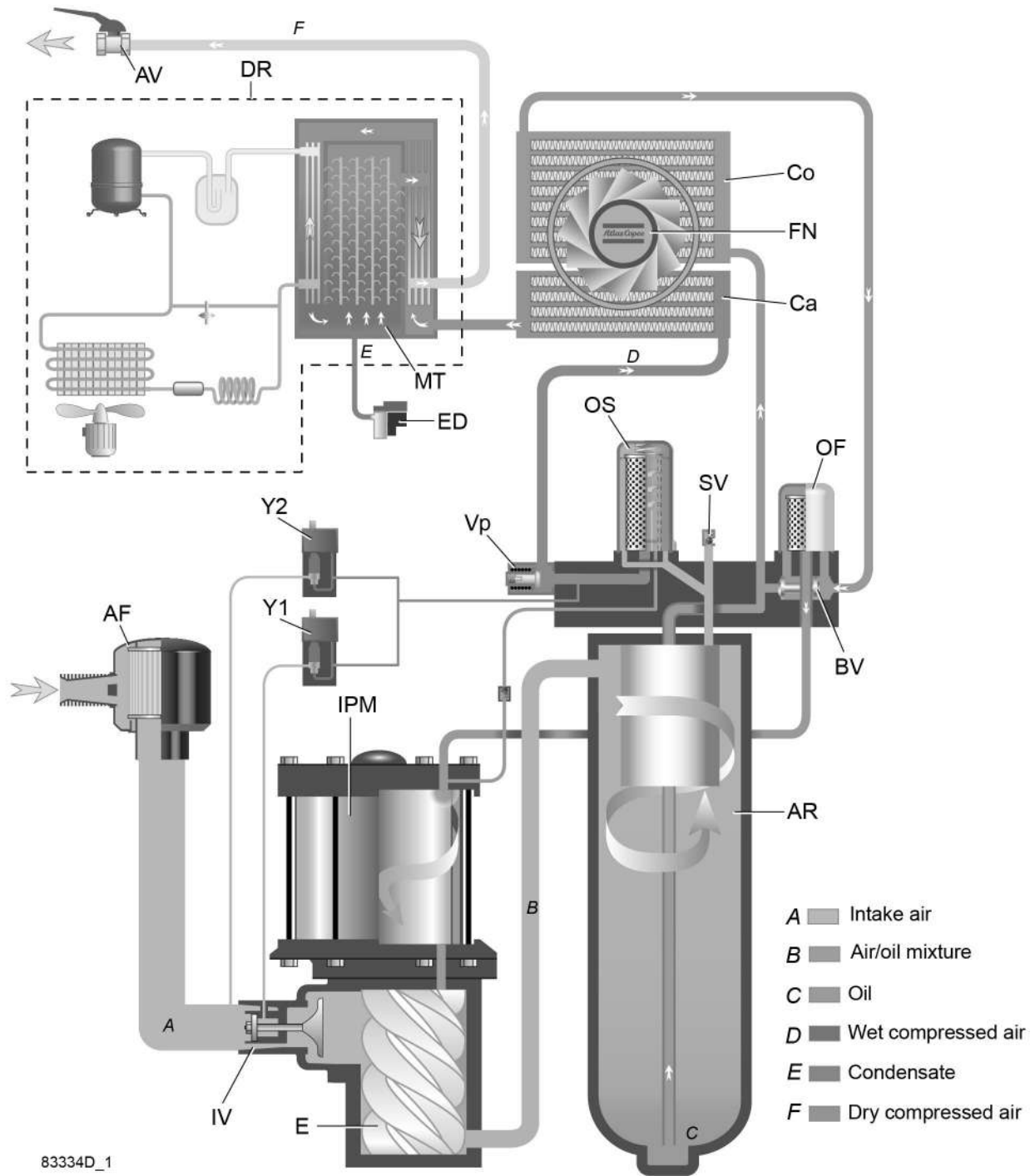

83334D_1

GA 7 VSD+ up to GA 15 VSD+ Workplace Full-Feature

Reference	Description
A	Air inlet
B	Air/oil mixture
C	Oil
D	Wet compressed air
E	Condensate

Reference	Description
F	Dry compressed air (Workplace Full-Feature)

Air flow

Air comes in through filter (AF) and inlet valve (IV) and is compressed in the compressor element (E).

A mixture of compressed air and oil flows into the air receiver/oil separator (AR), where oil and air are separated.

The air flows through the minimum pressure valve (Vp), the air cooler (Ca) and the condensate trap (MT) to the outlet valve (AV).

Minimum pressure valve (Vp) prevents the receiver pressure from dropping below a minimum pressure and includes a check valve which prevents blow-back of compressed air from the net.

Workplace Full-Feature compressors have a dryer (DR) after the air cooler.

Oil circuit

The air receiver (AR) removes most of the oil from the air/oil mixture by centrifugal action. The oil collects in the lower part of the air receiver (AR) which serves as oil tank.

The oil separator (OS) removes the remaining oil.

The oil circuit has a thermostatic bypass valve (BV) that prevents that the oil flows through the oil cooler (Co) when the oil temperature is low.

Air pressure forces the oil from air receiver (AR) through the oil filter (OF).

The filtered oil flows through the cooling channels of the interior permanent magnet (IPM) motor to the compressor element (E).

Cooling on air-cooled compressors

The cooling system has an air cooler (Ca) and an oil cooler (Co) (see [Flow diagram](#)).

The fan (FN) blows air over the coolers. This fan is set on and off, depending on the operating conditions, according to a specific algorithm.

2.3 Condensate system

Drain connections

The compressors have an electronic water drain (ED).

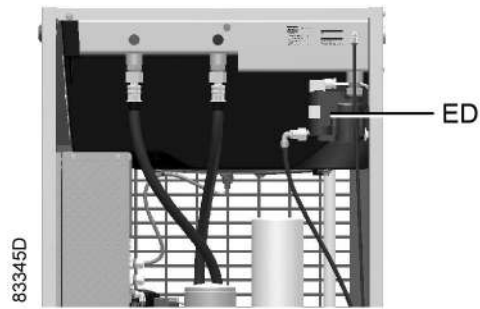

Location of the electronic water drain (Workplace)

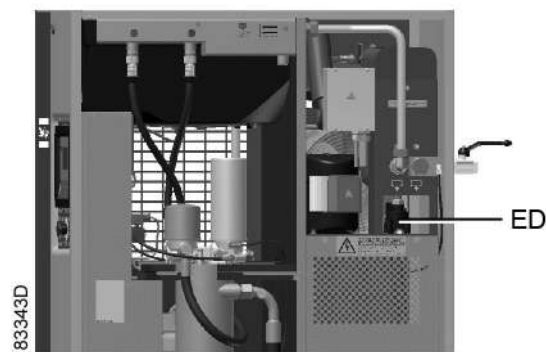

Location of the electronic water drains (Workplace Full-Feature)

On Workplace Full-Feature units, the condensate formed in the dryer collects in the lower part of the heat exchanger/evaporator.

When the condensate in the electronic drain reaches a certain level, it is drained via the automatic drain outlet (Da).

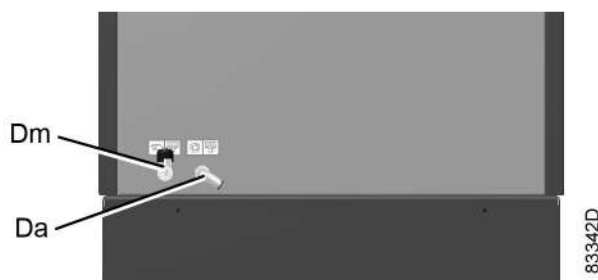

Condensate drain connections, Workplace

Reference	Designation
Da	Automatic drain connection
Dm	Manual drain connection

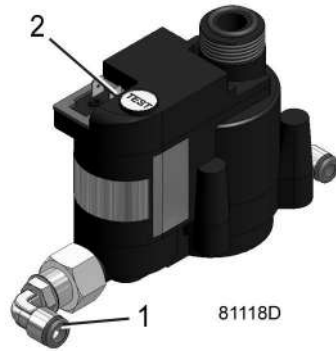

Electronic water drain (ED), typical view

The Test button (2) on top of the drain can be used in three different ways, according the situation:

- When pressed during normal operation, it starts the manual drain test.
- When pressed during an alarm, it resets the control logic.
- By pressing the Test button for at least 5 seconds, the self diagnosis routine will start.

2.4 Regulating system

Description

When the compressor is started and the net pressure is below the setpoint, the motor speed increases until the net pressure reaches the setpoint or until the maximum motor speed is reached.

If the air consumption is less than the air delivery of the compressor, the net pressure increases further.

When the net pressure reaches the setpoint (desired net pressure) and continues to rise, the regulator decreases the motor speed.

When the pressure continues to increase although the motor already operates at minimum speed, the regulator stops the motor as soon the net pressure reaches a value, equal to the setpoint plus the indirect stop level (typically 0.3 bar above the setpoint).

Should the net pressure rise very quickly to a value equal to the setpoint plus the direct stop level (typically 1 bar above the setpoint), the compressor is stopped immediately (without first decreasing the motor speed).

See section [Programmable settings](#).

No compressed air is lost when the compressor is stopped in automatic operation, thus saving valuable energy.

If the compressor was stopped in automatic operation and the net pressure approaches the setpoint, the regulator starts the motor again. The quicker the net pressure drops, the quicker the compressor will restart.



The pressure in the oil separator vessel is only released to atmosphere when the compressor is stopped manually or in case of an emergency stop (see chapter [Stopping](#) in section [Operating Instructions](#)).

2.5 Electrical system

Electric components

The electrical system has following components:

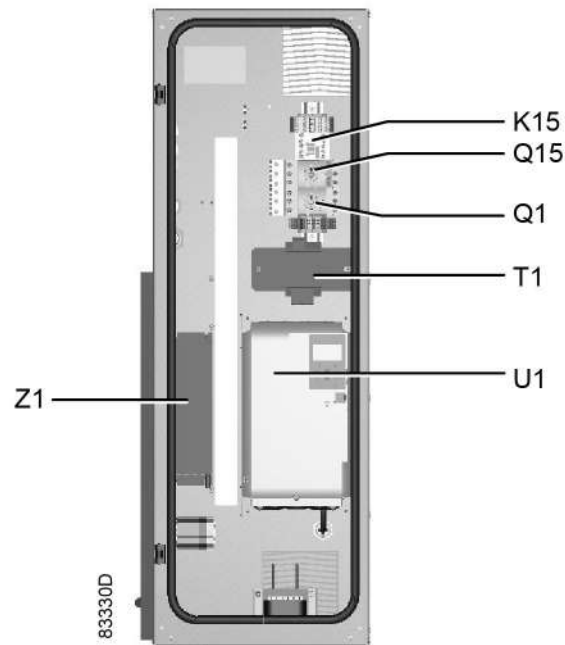

Electric cabinet, typical example

Reference	Designation
T1	Transformer
Q15	Circuit breaker
Q1	Circuit breaker
K15	Contactor
Z1	EMC filter
U1	Frequency converter

Electrical diagrams

The complete electric diagram can be found in the electrical cabinet and on the CD-ROM, DVD or USB, supplied with the unit.

2.6 Air dryer

Flow diagram

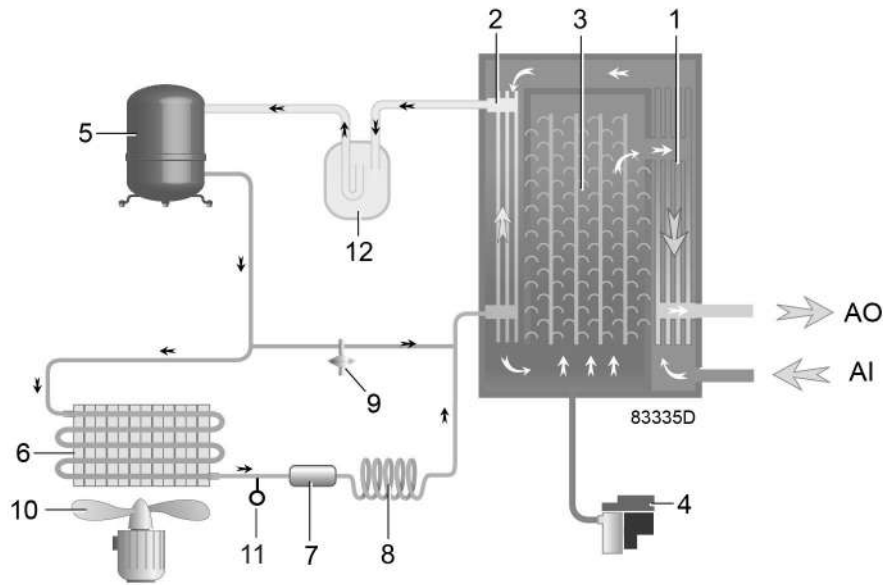

Air dryer

Reference	Name
AI	Air inlet
AO	Air outlet
1	Air/air heat exchanger
2	Air/refrigerant heat exchanger/evaporator
3	Condensate separator
4	Automatic drain / condensate outlet
5	Refrigerant compressor
6	Refrigerant condenser
7	Liquid refrigerant dryer/filter
8	Capillary
9	Bypass valve
10	Condenser cooling fan
11	Pressure switch, fan control
12	Liquid separator

Compressed air circuit

Compressed air enters the heat exchanger (1) and is cooled by the outgoing, cold, dried air.

Water in air starts to condense. Then, the air flows through the heat exchanger/evaporator (2), where the refrigerant evaporates.

This causes the air to cool further close to the evaporating temperature of the refrigerant. More water in the air condenses.

The cold air flows through the separator (3) where all the condensate gets out of the air.

The condensate is automatically drained through the outlet (4).

The outgoing, cold, dried air flows through the heat exchanger (1) where it is warmed up by the incoming compressed air.

Refrigerant circuit

The refrigerant compressor (5) delivers hot, high-pressure refrigerant gas which flows through the refrigerant condenser (6).

Most of the refrigerant condenses.

The liquid refrigerant flows through the liquid refrigerant dryer/filter (7) to the capillary tube (8).

The refrigerant leaves the capillary tube at about evaporating pressure.

The refrigerant enters the evaporator (2) where it gets heat from the compressed air by further evaporation at about constant pressure.

The heated refrigerant leaves the evaporator and gets into the compressor (5) through a liquid separator (12).

A bypass valve (9) regulates the refrigerant flow.

The fan (10) blows cool air over the refrigerant condenser (6).

Pressure switch (11) controls fan (10), depending on the operating conditions.

3 Elektronikon™ Touch controller

3.1 Controller



The Elektronikon™ Touch controller

Introduction

The controller has following functions:

- Controlling the unit
- Protecting the unit
- Monitoring components subject to service
- Automatic restart after voltage failure (ARAVF)

Automatic control of the unit

The controller maintains the net pressure between programmable limits by automatically loading and unloading the unit (fixed speed units) or by adapting the motor speed (units with frequency converter).

A number of programmable settings, e.g. the unloading and loading pressures (for fixed speed units), the setpoint (for units with frequency converter), the minimum stop time, the maximum number of motor starts and several other parameters are taken into account.

The controller stops the unit whenever possible to reduce the power consumption and restarts it automatically when the net pressure decreases. If the expected unloading period is too short, the unit is kept running to prevent too short standstill periods.



A number of time based automatic start/stop commands may be programmed. Take into account that a start command will be executed (if programmed and activated), even after manually stopping the unit.

Protecting the unit

Shutdown

Several sensors are provided on the unit. If one of the measured signals exceeds the programmed shutdown level, the unit will be stopped.

Example: If the element outlet temperature exceeds the programmed shutdown level, the unit will be stopped. This will be indicated on the display of the controller.

The unit will also be stopped in case of overload of the drive motor or fan motor.



Before remedying, consult the [Safety precautions](#).

Before resetting a warning or shutdown message, always solve the problem. Frequently resetting these messages without remedying may damage the unit.

Shutdown warning

A shutdown warning level is a programmable level below the shutdown level.

If one of the measurements exceeds the programmed shutdown warning level, a message will appear on the display and the general alarm LED will light up to warn the operator before the shutdown level is reached.

The message disappears as soon as the warning condition disappears.

A warning will also appear if the dew point temperature is too high (on units with integrated dryer).

When the shutdown warning is shown, press stop button to stop the unit and wait until the unit has stopped. Switch off the voltage, inspect the unit and remedy if necessary. The warning message will disappear as soon as the warning condition disappears.

Service warning

A number of service operations are grouped as a Service Plan. Each Service Plan has a programmed time interval. If the service timer exceeds a programmed value, this will be indicated on the display to warn the operator to carry out the service actions belonging to that Service Plan.

When the service warning is shown, stop the unit, switch off the voltage and carry out the required service actions. See section Preventive Maintenance.

Automatic restart after voltage failure (ARAVF)

The controller has a built-in function to automatically restart the unit when the voltage is restored after voltage failure. For units leaving the factory, this function is made inactive. If desired, the function can be activated. Consult your supplier.



If the function is activated and provided the regulator was in the automatic operation mode, the unit will automatically restart if the supply voltage to the module is restored. The ARAVF label (see section Pictographs) shall be glued near to the controller.

3.2 Control panel

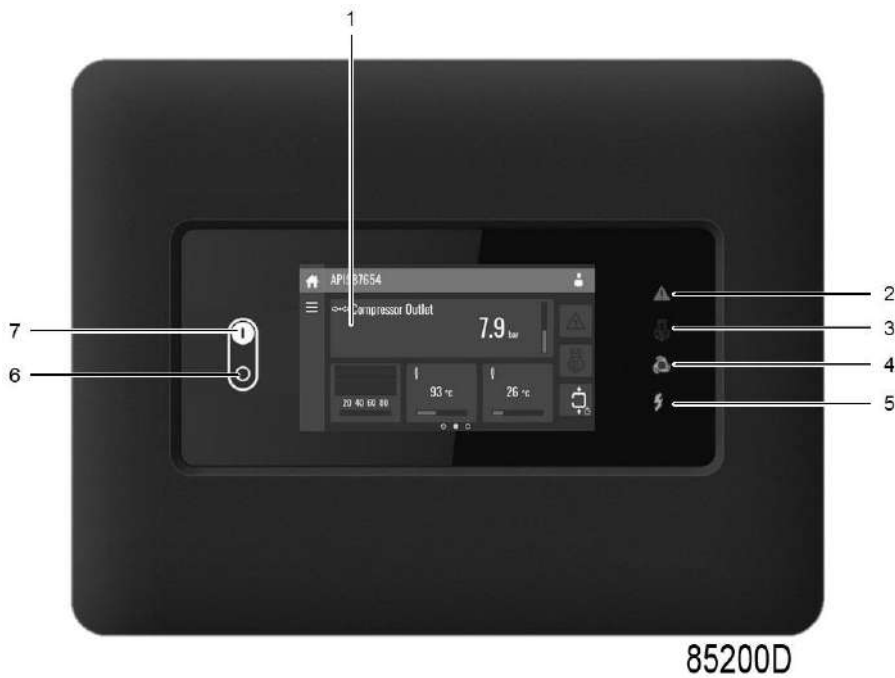

















Control panel





















Parts and functions

Reference	Designation	Function
1	Touchscreen	Shows the unit operating condition and a number of icons to navigate through the menu. The screen can be operated by touch.
2	Warning sign	Flashes in case of a shut-down, is lit in case of a warning condition.
3	Service sign	Is lit when service is needed.
4	Operation sign	Is lit when the unit is running in automatic operation.
5	Voltage sign	Indicates that the voltage is switched on.
6	Stop button	This button stops the unit.
7	Start button	This button starts the unit. The operation sign (4) lights up. The controller is operative.

3.3 Icons used







Menu icons

Menu	Icon	Menu	Icon	Menu	Icon
Data	 85233D	Status	 85239D		
		Inputs	 85240D		
		Outputs	 85241D		
		Counters	 85242D		
		Aux. Equipment Parameters	 85243D		
Service	 85234D	Service		Overview	 85252D
				Service Plan	 85253D
				Service History	 85254D
		Service functions	 85244D		
		Clean Screen	 85302D		
Week Timer	 85235D			Week	 85303D
				Remaining Running Time	 85304D
Event History	 85236D	Saved Data	 85245D		

Menu	Icon	Menu	Icon	Menu	Icon
Machine Settings	 85237D	Alarms	 85239D		
		Regulation	 85246D		
		Control Parameters	 85347D		
		Aux. Equipment Parameters	 85243D	Converter(s)	 85251D
		Auto Restart	 85274D	Fan	 85255D
				Internal SmartBox	 85256D
Controller Settings	 85238D	Network Settings	 85246D	Ethernet Settings	 85257D
				CAN Settings	 85258D
		Localisation	 85247D	Language	 85259D
				Date/Time	 85260D
				Units	 85261D
		User Password	 85248D		
		Help	 85249D		
Information	 85250D				

Status icons

Icon	Description
 85262D	Motor Stopped

 85263D	Motor Stopped Wait
 85264D	Running Unloaded
 85265D	Manual Unload
 85266D	Running Unloaded Wait
 85267D	Running Loaded
 85268D	Failed to Load
 85269D	Running Loaded Wait
 85270D	Manual Stop
 85271D	Machine Control Mode, Local
 85272D	Machine Control Mode, Remote
 85273D	Machine Control Mode, LAN
 85274D	Automatic Restart After Voltage Failure
 85275D	Week Timer Active

System icons

Icon	Description
 85276D	Basic User
 85277D	Advanced User
 85278D	Service User
 85279D	Antenna 25%

 85280D	Antenna 50%
 85281D	Antenna 75%
 85282D	Antenna 100%
 85283D	Change between screens (indication)
 85284D	Energy recovery
 85285D	Dryer
 85286D	Element
 85287D	Drain(s)
 85288D	Analogue Output
 85289D	Menu
 85290D	Reset
 85291D	Auto Restart
 85292D	Filter(s)
 85293D	Cooler
 85294D	Valve(s)
 85295D	Power Meter

Input icons

Icon	Description
 85296D	Pressure

 85297D	Temperature
 85298D	Special Protection
 85299D	Open
 85300D	Closed

	This chapter gives a general survey of available icons. Not all icons mentioned in this chapter are applicable to every machine.
---	--

3.4 Main screen

Function

The Main screen is the screen that is shown automatically when the voltage is switched on. It is switched off automatically after a few minutes when there is no touch input.

Description

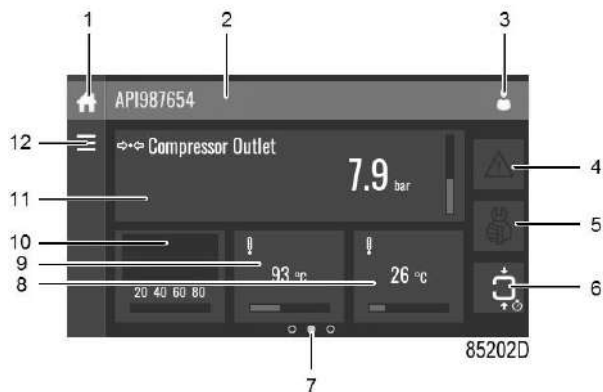

Reference	Designation	Function
1	Home button	The home button is always shown and can be tapped to return to the main screen.
2	Screen information	On the main screen, the screen information bar shows the serial number of the machine. When scrolling through menus, the name of the current menu is shown.
3	Access level button	The access level button is always shown and can be tapped to change the current user access level.

Reference	Designation	Function
4	Alarm button	The alarm button can be tapped to show the current alarms. If an alarm occurs, the icon on the button will be red.
5	Service button	The service button can be tapped to show the service information.
6	Status	This icon shows the current status of the unit.
7	Page indicator	Indicates which page you currently see. The middle indication is the main screen, left is the menu screen and at the right the quick access screen. Swipe left or right to go to another screen.
8, 9, 10, 11	These fields can contain a history chart, an input or a counter value, depending on the type of the machine.	Tap the field to view the type of measurement. This will be shown in the screen information bar. Examples of inputs: <ul style="list-style-type: none"> • Ambient temp • Outlet • Dryer dewpoint Examples of counters: <ul style="list-style-type: none"> • Running hours • Load relay • Loaded hours
12	Menu button	The menu button is always shown and can be tapped to go to the menu.

3.5 Quick access screen

Function

The screen is used to directly access some frequently used functions.

Procedure

The Quick access screen can be viewed by swiping left, starting from the main screen.

Description



Through this screen, several important settings can be viewed and modified.

Function	Description
Setpoints	Several setpoints can be modified by tapping this icon.
Control mode	The control mode can be changed by tapping this icon. <ul style="list-style-type: none"> • Local control via start/stop buttons • Remote control via digital input(s) • LAN control via the network. When in Remote or LAN control, the start/stop buttons on the controller will not work.
Display language	The display language of the controller can be changed by tapping this icon.
Manual unload (only on fixed speed units)	When tapped, the machine will go in Manual unload mode until the icon is tapped again.
Week timer	Week timers can be set by tapping this icon.
Remaining running time	The Remaining running time can be set and modified by tapping this icon.
Internal SmartBox	The reception quality of the internal antenna can be monitored. <div style="text-align: center;">  </div> Each bar represents 25% reception strength. If the four bars are filled, the reception strength is 100%. If only one bar is filled, the reception strength is just 25%.
Auto restart	Auto restart can be activated by tapping this icon.

3.6 Menu screen

Function

This screen is used to display the different menus where settings can be viewed or changed.

Procedure

The Menu screen can be viewed by tapping the Menu button or by swiping right, starting from the main screen.

Description



Reference	Designation	Function
(1)	Data	The data menu contains the status of the unit, information about the Inputs, Outputs and Counters. The Auxiliary equipment can also be viewed through this menu.

Reference	Designation	Function
(2)	Service	The service menu contains the Service information. The 'Clean screen' function can be used to clean the touchscreen.
(3)	Week timer	Multiple Week timers and a Remaining running time can be set through this menu.
(4)	Event history	In case of an alarm, the Status information of the unit is saved and can be viewed through this menu.
(5)	Machine settings	Alarms settings, Regulation settings and Control parameters can be changed through this menu. Auxiliary equipment parameters can also be changed. The Auto restart function can be set through this menu. This function is password protected.
(6)	Controller settings	Network settings, Localisation settings and a User password can be set through this menu. There is also a Help page available and the Controller information can be shown.

Menu structure

Operating the controller can be done by swiping through screens and tapping icons or menu items.

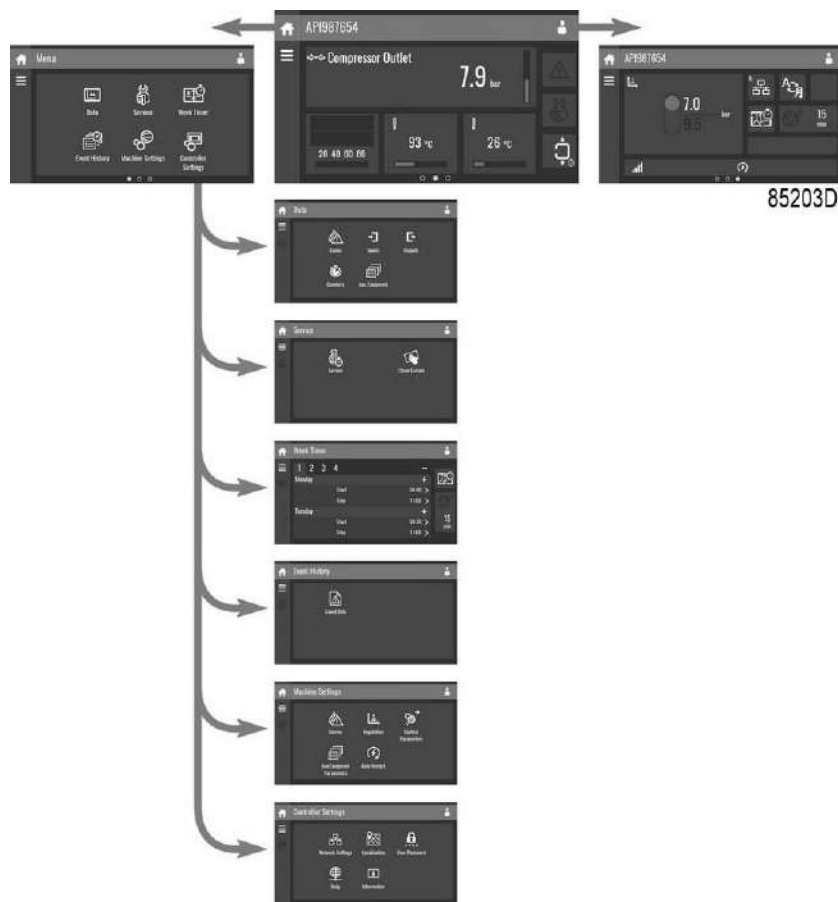

This is the main menu structure. The structure can be different depending on the configuration of the unit.

3.7 Data menu

Function

This screen is used to display the following submenus:

- Status
- Inputs
- Outputs
- Counters
- Aux. Equipment

These submenus can be entered by tapping the icons.

Procedure

To enter the Data menu screen:

1. Tap the Menu button
2. Tap the Data icon

Description



Reference	Designation
(1)	Status menu
(2)	Inputs menu
(3)	Outputs menu
(4)	Counters menu
(5)	Auxiliary equipment menu

Status menu

Tap the Status icon to enter the Status menu.

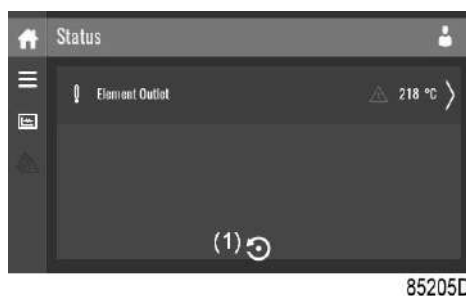

This menu shows the current status of the unit.

If an alarm is active, it can be viewed by tapping the alarm message. To reset an alarm, tap the reset button (1).

	<p>Before remedying, consult the Safety precautions. Before resetting a warning or shutdown message, always solve the problem. Frequently resetting these messages without remedying may damage the unit.</p>
--	--

Inputs menu

Tap the Inputs icon to enter the Inputs menu.

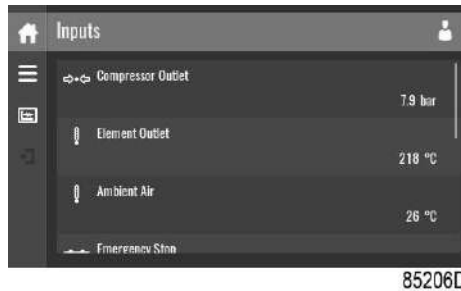

85206D

This menu shows information about all the inputs.

Outputs menu

Tap the Outputs icon to enter the Outputs menu.



85207D

This menu shows information about all the outputs.

	<p>Voltage-free outputs may only be used to control or monitor functional systems. They should NOT be used to control, switch or interrupt safety related circuits. Check the maximum allowed load on the label.</p>
	<p>Stop the unit and switch off the supply before connecting external equipment. Check the Safety precautions.</p>

Counters menu

Tap the Counters icon to enter the Counters menu.

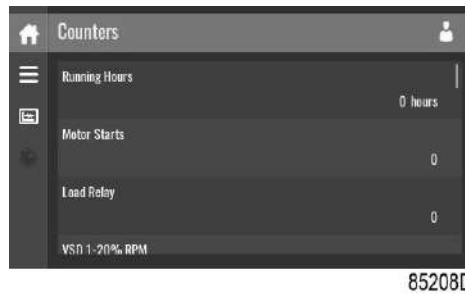

85208D

This menu shows an overview of all actual hours and counters of the unit and controller.

Auxiliary equipment menu

Tap the Aux. Equipment icon to enter the Aux. equipment menu.

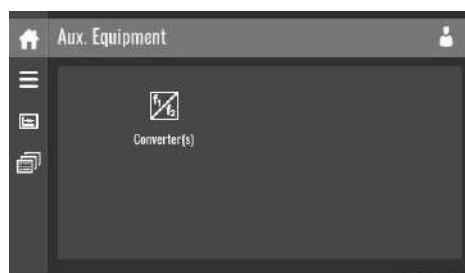

85209D

This menu shows an overview of all auxiliary equipment fitted.

3.8 Service menu

Function

This screen is used to display the following submenus:

- Service
- Service functions (Only visible as advanced user)
- Clean screen

These submenus can be entered by tapping the icons.

Procedure

To enter the Service menu screen:

1. Tap the Menu button
2. Tap the Service icon

Description

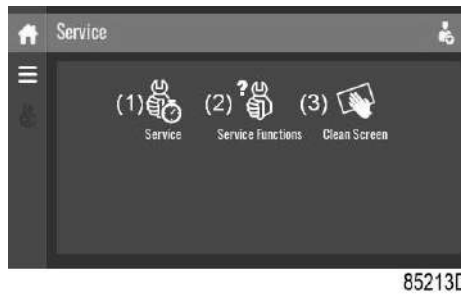

Reference	Designation
(1)	Service
(2)	Service functions (Only visible as advanced user)
(3)	Clean screen

Service menu

Tap the Service icon to enter the Service menu.

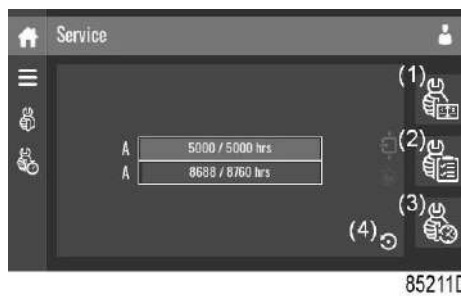

This menu shows the remaining Running Hours and the remaining Real Time Hours until the next service. The first row (A) shows the Running Hours when the first service is needed (green), the second row shows the Real Time Hours (blue)

A service overview can be viewed by tapping icon (1).

The service plan can be viewed by tapping icon (2). Through this menu, the service plan can be modified:

1. Tap the desired service plan. A selection screen will pop up.
2. Change the Running Hours by tapping ‘-’ or ‘+’.
3. Confirm by tapping ‘V’ or decline by tapping ‘X’.

The service history can be viewed by tapping icon (3).

When a service plan interval is reached, a message will appear on the screen. When service has been performed, the service timer can be reset by tapping the reset button (4).

Service functions (Only visible as advanced user)

Tap the Service Functions icon to enter the Service Functions menu.

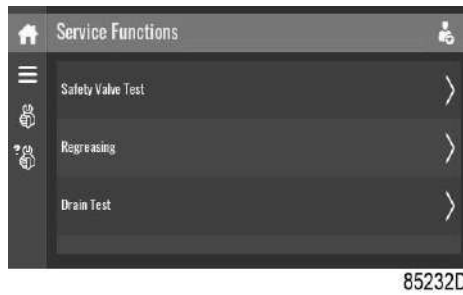

85232D

Depending on the machine, this menu can have a different set of functions. Many of them are password protected, as they are only accessible for authorized personnel.

Clean screen

Tap the Clean Screen icon to start the 15 seconds countdown to perform cleaning of the touchscreen.

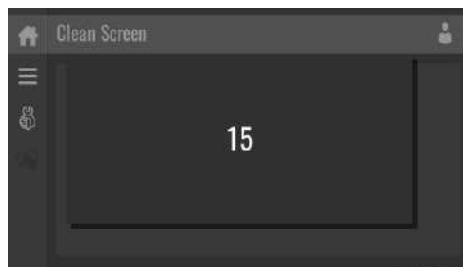

85212D

The touchscreen and the start and stop button become inactive for 15 seconds.

3.9 Week timer menu

Function

This screen is used to set up to 4 different week timers with each up to 8 settings per day.

The week timers can be activated through this screen.

A Remaining Running Time can be set from 5 up to 240 minutes.

Procedure

To enter the Week Timer menu screen:

1. Tap the Menu button
2. Tap the Week Timer icon

Description



85214D

Reference	Designation	Function
(1)	Add or select week	If less than 4 weeks are programmed, tap the '+' button to add a week.
(2)	Remove week	Tap to remove a programmed week timer.
(3)	Activate week timer	A selection screen pops up. The user can choose the correct week by tapping '-' or '+' and can confirm by tapping 'V' or decline by tapping 'X'.
(4)	Remaining running time	A selection screen pops up. The user can change the remaining time by tapping '-' or '+' and can confirm by tapping 'V' or decline by tapping 'X'.
(5)	Add setting	A selection screen pops up. The user can change the setting by swiping up or down and confirm by tapping 'V' or decline by tapping 'X'.

3.10 Event history menu

Function

This screen is used to display the saved data in case of an alarm.

These submenus can be entered by tapping the icons.

Procedure

To enter the Event history menu screen:

1. Tap the Menu button
2. Tap the Event History icon

Description

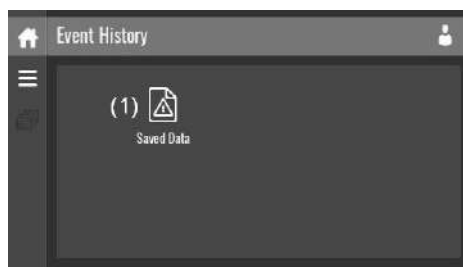

85216D

Reference	Designation
(1)	Saved Data

Saved data

Tap the Saved Data icon to enter the Saved Data menu.

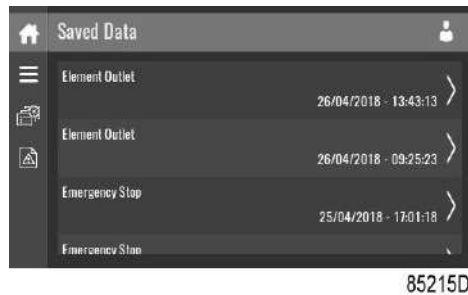

Scroll through the items swiping up and down in this list. The event date and time is shown at the right side of the screen.

Press on one of the items in the list for more information reflecting the status of the unit when the shutdown occurred.

3.11 Machine settings menu

Function

This screen is used to display the following submenus:

- Alarms
- Regulation
- Control Parameters
Only visible if the machine has adaptable parameters.
- Aux. Equipment parameters
- Auto Restart

These submenus can be entered by tapping the icons.

Procedure

To enter the Machine settings menu screen:

1. Tap the Menu button
2. Tap the Machine Settings icon

Description

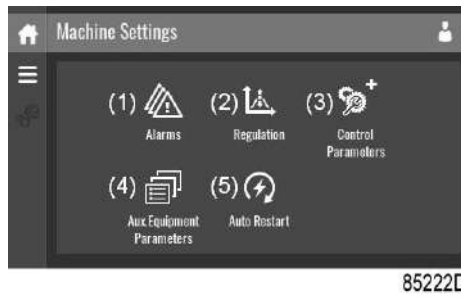

Reference	Designation
(1)	Alarms menu
(2)	Regulation menu
(3)	Control Parameters menu
(4)	Aux. Equipment Parameters menu
(5)	Auto Restart menu

Alarms menu

Tap the Alarms icon to enter the Alarms menu.

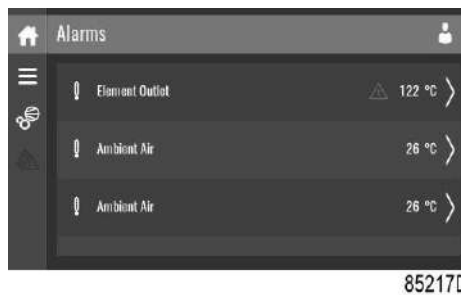

A list of all alarms is shown.

When pressing on one of the items in this list, the warning and/or shutdown levels are shown for this alarm.

Regulation menu

Tap the Regulation icon to enter the Regulation menu.



Setpoints or pressure bands can be modified through this menu.

Modify a setting

When tapping a list item, a selection screen pops up. The user can modify the setting by tapping '–' or '+' and can confirm by tapping 'V' or decline by tapping 'X'.

Change a selection

When tapping a list item, a selection screen pops up. The user can change the selection by swiping up or down and confirm by tapping 'V' or decline by tapping 'X'.

Control parameters menu

Tap the Control Parameters icon to enter the Control Parameters menu.

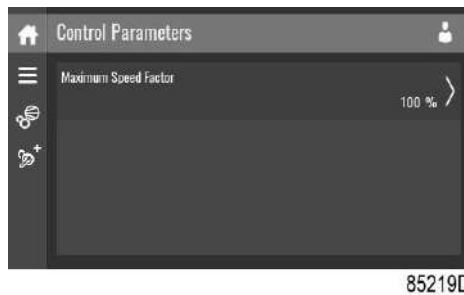

This menu shows information about the Control Parameters.

Modify a setting

When tapping a list item, a selection screen pops up. The user can modify the setting by tapping '–' or '+' and can confirm by tapping 'V' or decline by tapping 'X'.

Auxiliary equipment parameters menu

Tap the Aux. Equipment Parameters icon to enter the auxiliary equipment parameters menu.

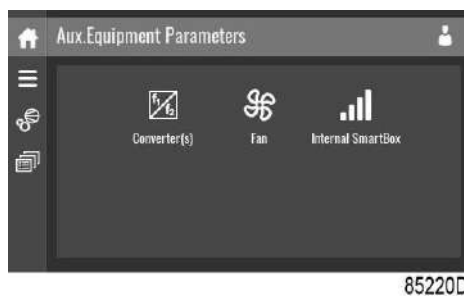

This menu shows an overview of all the auxiliary equipment fitted.

Through this menu, the parameters of the auxiliary equipment can be changed.

Modify a setting

When tapping a list item, a selection screen pops up. The user can modify the setting by tapping '–' or '+' and can confirm by tapping 'V' or decline by tapping 'X'.

Auto restart menu

Tap the Auto restart icon to enter the Auto Restart menu.

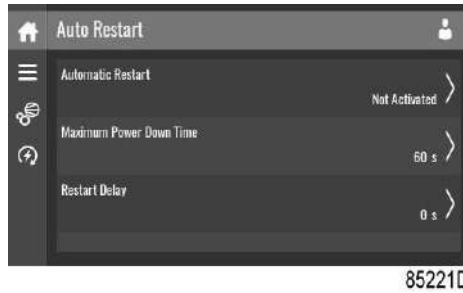

Through this menu, the automatic restart can be activated. The activation is password protected. The automatic restart settings can also be changed.

Enter a password

When tapping a password protected item, a selection screen pops up. The user can enter the password by swiping up or down to select the desired number. Once the 4 digits are entered, the user can confirm by tapping 'V' or decline by tapping 'X'.

Modify a setting

When clicking a list item, a selection screen pops up. The user can modify the setting by tapping '-' or '+' and can confirm by tapping 'V' or decline by tapping 'X'.

3.12 Controller settings menu

Function

This screen is used to display the following submenus:

- Network Settings
- Localisation
- User Password
- Help
- Information

These submenus can be entered by tapping the icons.

Procedure

To enter the Controller Settings menu screen:

1. Tap the Menu button
2. Tap the Controller Settings icon

Description

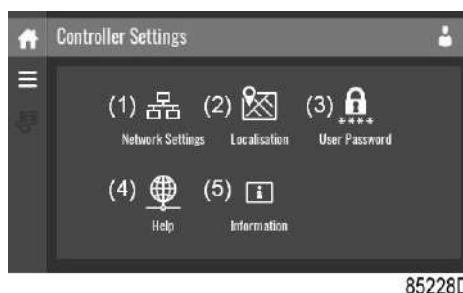

Reference	Designation
(1)	Network Settings menu
(2)	Localisation menu
(3)	User Password menu
(4)	Help menu
(5)	Information menu

Network settings menu

Tap the Network Settings icon to enter the Network Settings menu.

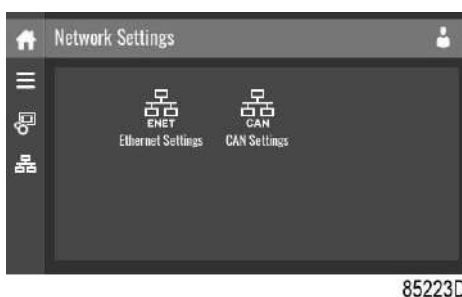

Ethernet Settings

The list of Ethernet Settings is shown. When ethernet is turned off, the settings can be modified.

CAN Settings

The list of CAN Settings is shown. When CAN is turned off, the settings can be modified.

Modify a setting

When tapping a list item, a selection screen pops up. The user can modify the setting by tapping '-' or '+' and can confirm by tapping 'V' or decline by tapping 'X'.

Change a selection

When tapping a list item, a selection screen pops up. The user can change the selection by swiping up or down and confirm by tapping 'V' or decline by tapping 'X'.

Localisation menu

Tap the Localisation icon to enter the Localisation menu.



Language

The language setting of the controller can be modified through this menu.

Date/Time

The date and time settings of the controller can be modified through this menu.

Units

The units displayed can be modified through this menu.

Modify a setting

When tapping a list item, a selection screen pops up. The user can modify the setting by tapping ‘-’ or ‘+’ and can confirm by tapping ‘V’ or decline by tapping ‘X’.

Change a selection

When tapping a list item, a selection screen pops up. The user can change the selection by swiping up or down and confirm by tapping ‘V’ or decline by tapping ‘X’.

User password menu

Tap the User Password icon to enter the User Password menu.



The user password can be activated or deactivated through this menu. Enter and confirm a user password to activate, repeat to deactivate.

Enter a password

When tapping a password protected item, a selection screen pops up. The user can enter the password by swiping up or down to select the desired number. Once the 4 digits are entered, the user can confirm by tapping ‘V’ or decline by tapping ‘X’.

Help menu

Tap the Help icon to enter the Help menu.



This menu can show a link to the web page of your supplier, a helpdesk phone number or other helpful information.

Information menu

Tap the Information icon to enter the Information menu.



This menu shows information about the controller.

3.13 Access level

Function

Through this pop-up screen the access level settings can be viewed or changed.

Procedure

The Access Level screen can be viewed or changed by tapping the Access Level button at the upper right corner of the screen.

Description



Reference	Designation	Function
(1)	User	A basic set of parameters is visualized, no password required.
(2)	Service	A basic set of parameters can be modified, no password required.
(3)	Full	This access level is not accessible to end users.
(4)	Decline	Tap to decline the selected user level.
(5)	Confirm	Tap to confirm the selected user level.

Service access level



Tap the Service access level icon (1) and confirm (2).



The screen information bar (1) now shows the current status of the unit instead of the machine serial number.

The Received Signal Strength Indicator (RSSI) value is now shown in the Internal SmartBox menu. See [Quick access screen](#).

In the service menu, an extra menu item is now available. See [Service menu](#).

4 Installation

4.1 Dimension drawings

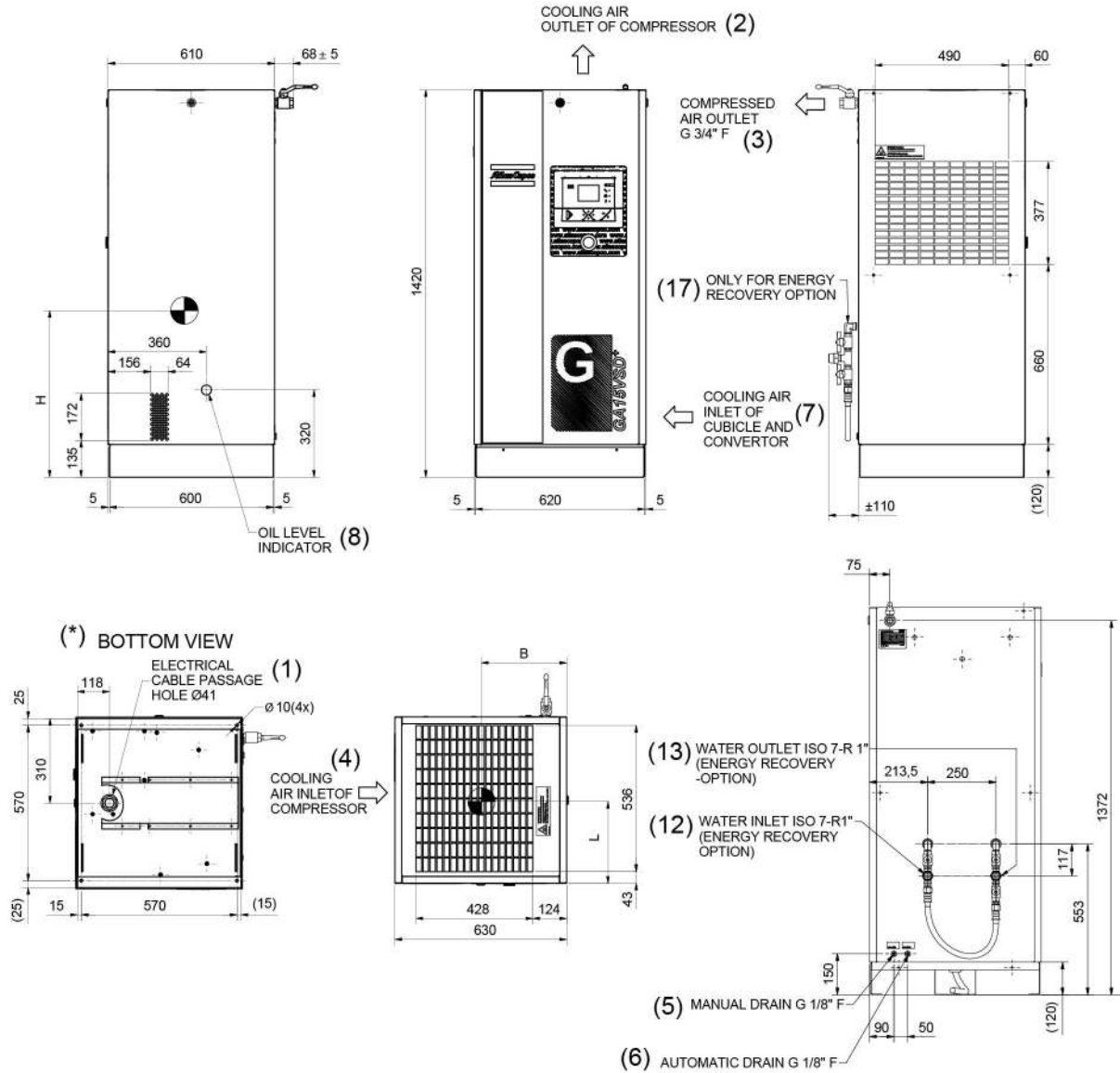

9820 6950 00

83324D

Centre of gravity and weight

Type	L (mm)	B (mm)	H (mm)	Weight (kg)
GA 7 VSD+	335	315	600	188
GA 11 VSD+	325	300	610	191
GA 15 VSD+	315	290	630	194

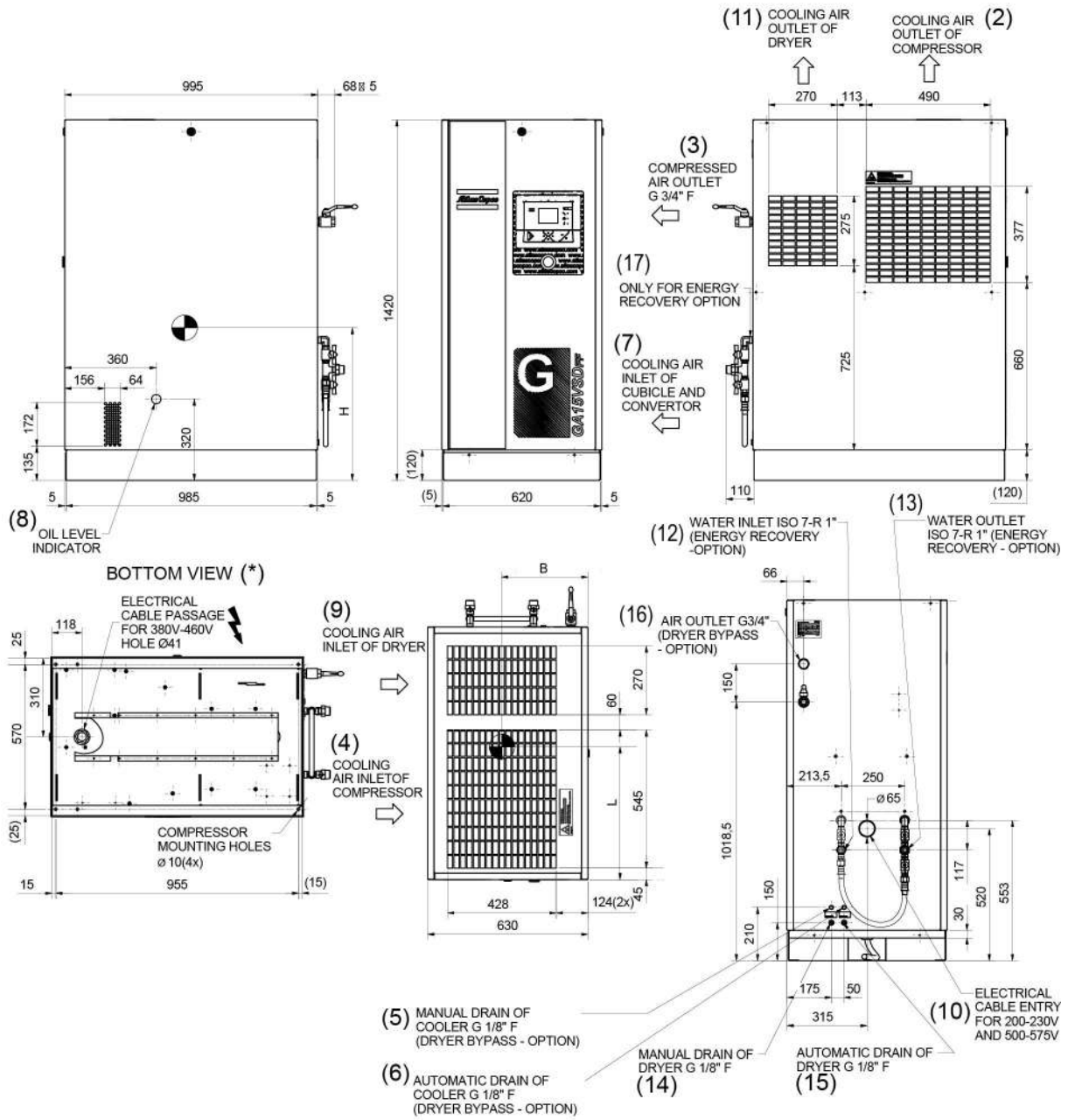

9820 6950 10

83325D

Centre of gravity and weight

Type	L (mm)	B (mm)	H (mm)	Weight (kg)
GA 7 VSD+ 200-230V	475	340	560	287
GA 7 VSD+ 500-575V	440	330	580	253
GA 7 VSD+ FF 200-230V	520	340	580	332
GA 7 VSD+ FF 380-460V	475	320	610	268
GA 7 VSD+ FF 500-575V	500	330	600	298
GA 11 VSD+ 200-230V	485	330	570	314
GA 11 VSD+ 500-575V	445	320	590	268

Type	L (mm)	B (mm)	H (mm)	Weight (kg)
GA 11 VSD+ FF 200-230V	525	330	590	359
GA 11 VSD+ FF 380-460V	465	300	620	271
GA 11 VSD+ FF 500-575V	500	320	610	313
GA 15 VSD+ 200-230V	495	320	580	345
GA 15 VSD+ 500-575V	445	310	600	281
GA 15 VSD+ FF 200-230V	535	320	600	395
GA 15 VSD+ FF 380-460V	465	290	630	279
GA 15 VSD+ FF 500-575V	500	310	620	331

Dimensions +/- 10 mm

Weights (oil included) +/- 10 kg

Reference	Designation
1	Electric cable entry for 380 V - 460 V
2	Compressor cooling air outlet
3	Compressor air outlet
4	Compressor and cooling air inlet
5	Manual drain compressor
6	Automatic drain compressor
7	Cubicle and converter cooling air inlet
8	Oil level indicator
9	Dryer cooling air inlet
10	Electric cable entry for 200 - 230 V and 500 - 575 V
11	Dryer cooling air outlet
12	Water inlet (Energy recovery)
13	Water outlet (Energy recovery)
14	Manual drain dryer
15	Automatic drain dryer
16	Compressor air outlet (Dryer bypass option)
17	Only for energy recovery option
*	Bottom view

4.2 Installation proposal

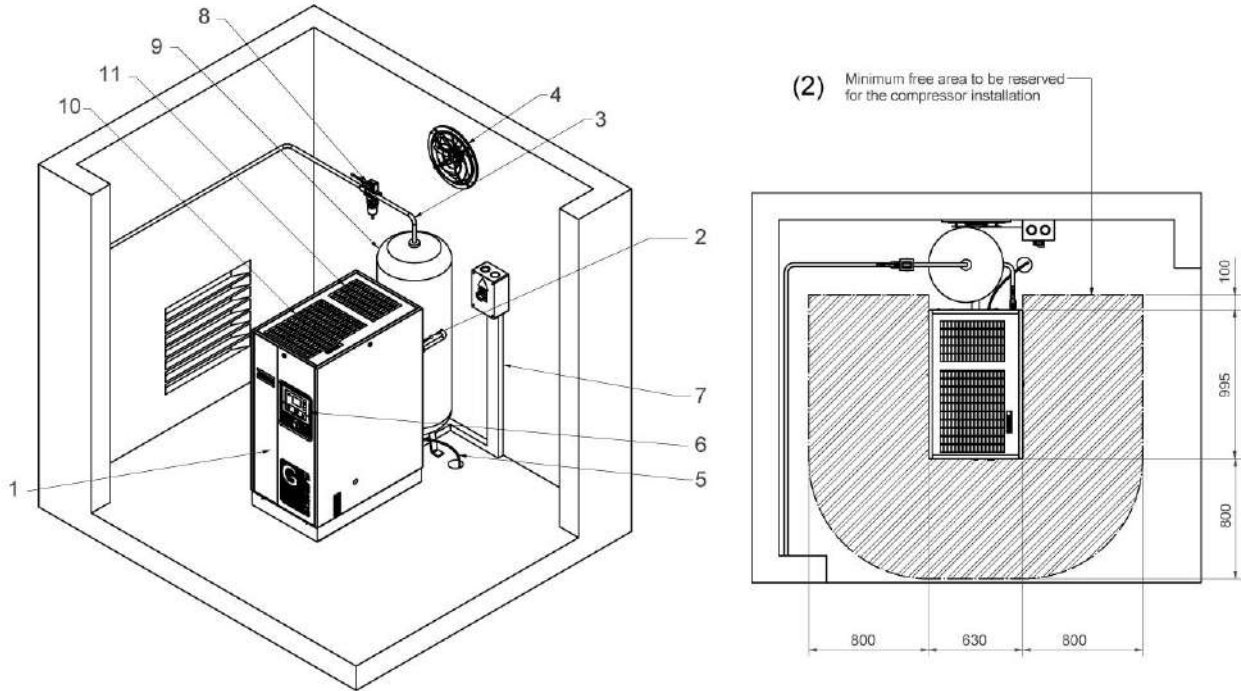

VENTILATION PROPOSALS (1)

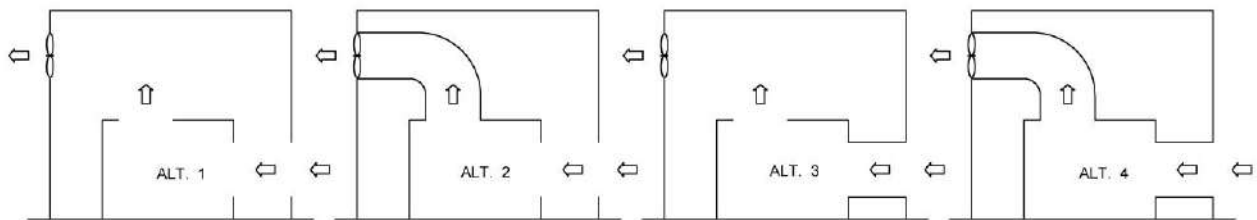

9820 6950 11
83326D

Compressor room example

Text on image

(1)	Ventilation proposals
(2)	Minimum free area to be reserved for the compressor installation

Description

1	Compressor unit: Install the compressor unit on a solid, level floor suitable for taking the weight.
2	Position of the compressed air outlet valve.

<p>3</p>	<p>Delivery pipe: The pressure drop over the air delivery pipe can be calculated as follows: $\Delta p = (L \times 450 \times Q_c^{1.85}) / (d^5 \times P)$, with d = inner diameter of the pipe in mm Δp = pressure drop (recommended maximum: 0.1 bar (1.5 psi)) L = length of the pipe in m P = absolute pressure at the compressor outlet in bar(a) Q_c = free air delivery of the compressor in l/s Connect air outlet pipe of the compressor on top of the main air net pipe. In this way, there is a minimum carry-over of condensate residue.</p>
<p>4</p>	<p>Ventilation: When you install the inlet grids and ventilation fan, make sure that no re-circulation of cooling air into the compressor or into the dryer is possible. The maximum air velocity through the grids is 5 m/s (16.5 ft/s). The maximum air temperature at the compressor intake is 46 °C (115 °F). The minimum air temperature at the compressor intake is 0 °C (32 °F). Alternatives 1 and 3: the required ventilation to limit the compressor room temperature is calculated as follows:</p> <ul style="list-style-type: none"> • Q_v = 1.19 N/ΔT (for units without dryer) • Q_v = 1.25 N/ΔT (for units with dryer) <p>Q_v = Required ventilation capacity in m³/s N = Shaft input of compressor in kW ΔT = Temperature increase in compressor room in °C Alternatives 2 and 4: Make sure that the cooling air duct of the air/oil cooler is separated from the cooling air duct of the dryer. The maximum pressure drop over the additional air/oil ducts is limited to 10 Pa (0.04 in wc) for the standard fan.</p>
<p>5</p>	<p>Drain pipes: Connect the condensate drain outlets to a drain collector. See section Condensate system for the position of the outlets. The drain pipes to the drain collector must not dip into the water. If the pipes lead outside the room where freezing is possible, they must be insulated. Atlas Copco has oil/water separators (type OSD or OSCi) to separate the major part of the oil from the condensate to ensure that the condensate meets the requirements of the environmental codes.</p>
<p>6</p>	<p>Control module with monitoring panel.</p>
<p>7</p> 	<p>Power supply cable: Have the power supply cable sized and installed by a qualified electrician. In case of an IT network, consult Atlas Copco. To preserve the protection degree of the electric cubicle and to protect its components from dust from the environment, it is mandatory to use a proper cable gland when connecting the supply cable to the compressor.</p>
<p>8</p>	<p>Filter, type DD for general purposes The filter traps solid particles down to 1 micron with a maximum oil carry-over of 0.5 mg/m³. A high-efficiency filter, type PD, may be installed downstream of a DD filter. This filter traps solid particles down to 0.01 micron with a maximum. oil carry-over of 0.01 mg/m³. If oil vapours and odours are undesirable, install a QD type filter downstream of the PD filter. Install bypass pipes over each filter together with ball valves. This ensures that service operations do not disturb the compressed air delivery .</p>
<p>9</p>	<p>Air tank: Install the air tank (optional) in a frost free room, on a solid level floor suitable for taking the weight. Install a safety valve on the air tank.</p>

10	Outlet cooling air grating of the air cooler and the oil cooler.
11	Outlet cooling air grating of the dryer.
12	Bypass system to bypass the dryer during service operations (available as an option, consult Atlas Copco).

Safety

	Apply all relevant safety precautions, including those mentioned in this book.
---	--

Outdoor/altitude operation

The compressors are not designed for outdoor use.

The compressors can only be used in temperatures above 0 °C (+32 °F). If frost might occur, the appropriate measures should be taken to avoid damage to the machine and its ancillary equipment. In this case, consult Atlas Copco.

Also if operating above 1000 m (3300 ft), consult Atlas Copco.

Moving/lifting

The compressor can be moved by a lift truck using the slots in the frame. Take care not to damage the bodywork during lifting or transport. Before lifting, reinstall the transport securing bolts. Make sure that the forks protrude from the other side of the frame. The compressor can also be lifted after inserting beams in the slots. Make sure that the beams cannot slide and that they protrude from the frame equally. The chains must be held parallel to the bodywork by chain spreaders in order not to damage the compressor. The lifting equipment must be placed in such a way that the compressor is lifted perpendicularly. Lift gently and avoid twisting.

	In case of units equipped with the Lifting Device Option, it is not allowed to lift the compressor if the canopy parts or lifting supports are not completely installed. When the compressor is being lifted, it is also forbidden to come under the load or to perform maintenance activities to it.
---	---

Acclimatization

	When moving the compressor into an installation room, forming of condense can occur on some components. To avoid dew harming of electrical components, ensure at least 2 hours of acclimatization before switch on the compressor.
---	---

4.3 Electrical connections

	<p>Working with machinery controlled by a frequency converter requires special safety precautions. These safety precautions depend on the kind of network used (TN, TT, IT system). Consult Atlas Copco.</p>
---	--

	<p>Most compressors are designed for use in TT/TN networks and are intended for industrial environments where the electrical supply is separated from the residential/commercial supply network. To use the machine in light industrial, commercial or residential environments with a shared supply network or in an IT network, extra measures can be required: contact Atlas Copco.</p>
---	--

Electrical connections for GA 7 VSD+ up to GA 15 VSD+

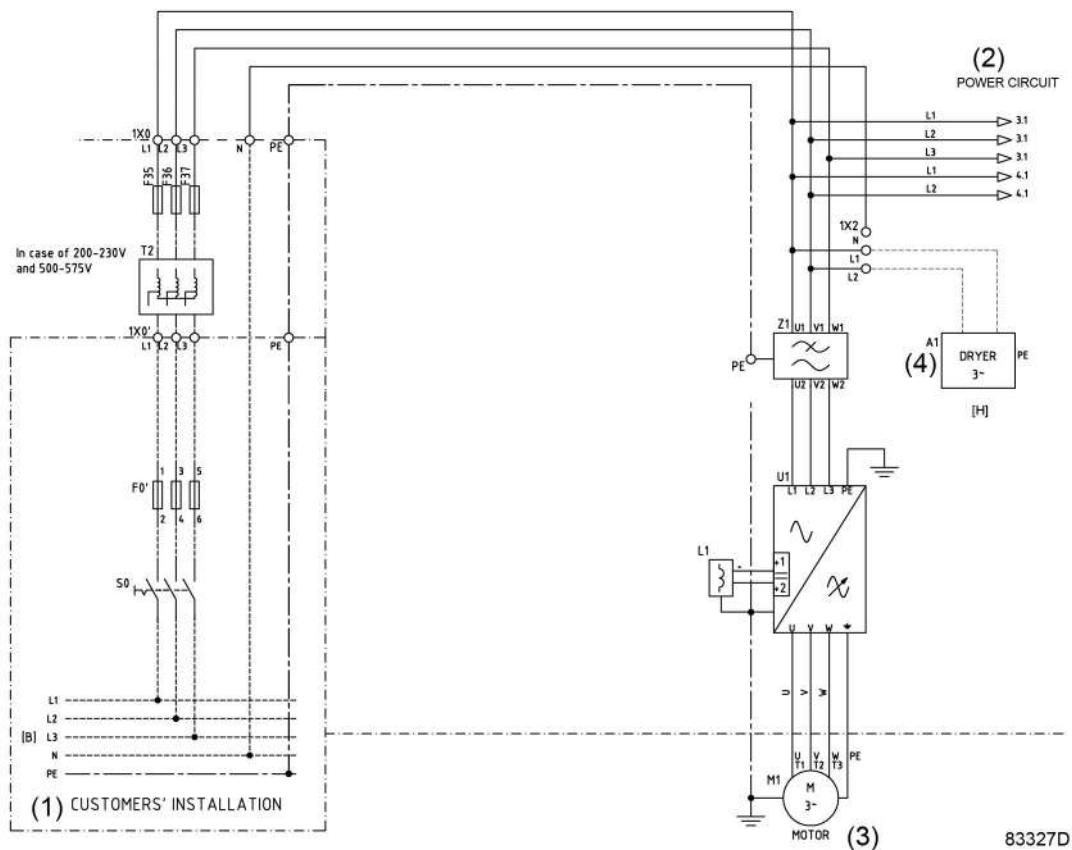

Electrical connections diagram, typical example

Reference	Designation
(1)	Customer's installation
(2)	Power circuit
(3)	Motor
(4)	Dryer

Note

The complete electrical diagram can be found in the electrical cubicle.

Description

	You find the correct position for the electrical connection on the Dimension drawings .
---	---

1. Provide an isolating switch.
2. Check that the motor cables and wires inside the electric cabinet are clamped tight to their terminals.
3. Check the fuses. See section [Electric cable size and fuses](#).
4. Connect the power supply cables to terminals (1, 3 and 5).
5. Connect the earth conductor to the earth bolt (PE).

	To preserve the protection degree of the electric cubicle and to protect its components from dust from the environment, it is mandatory to use a proper cable gland when connecting the supply cable to the compressor.
---	---

Compressor control modes

The following control modes can be selected:

- **Local control:** The compressor will react to commands entered by means of the buttons on the control panel. Compressor start/stop commands via Clock function are active, if programmed.
- **Remote control:** The compressor will react to commands from external switches. Emergency stop remains active. Compressor start/stop commands via Clock function are still possible.

	Have the modifications checked by Atlas Copco. Stop the compressor and switch off the voltage before connecting external equipment. Only potential free contacts are allowed.
---	---

- **LAN control:** The compressor is controlled via a local network. Consult Atlas Copco.

Compressor status indication

The Elektronikon controller is provided with potential free auxiliary NO contacts (NO = normally open) (K05, K07 and K08) for remote indication of:

- Manual or automatic operation (K07)
- Warning condition (K08)
- Shutdown condition (K05)

Maximum contact load: 10 A / 250 V AC.

Stop the compressor and switch off the voltage before connecting external equipment. Consult Atlas Copco.

4.4 Pictographs

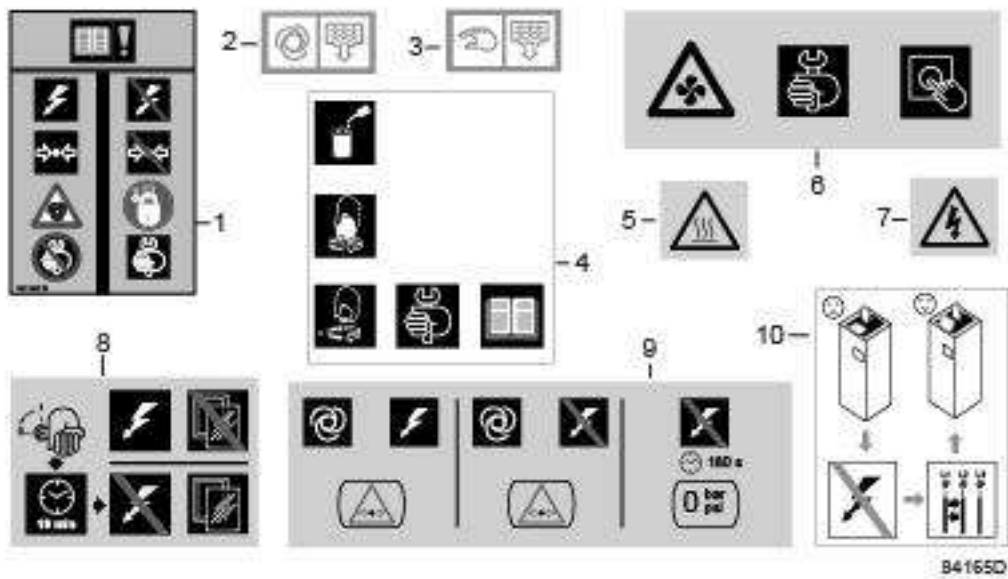

Pictographs

Reference	Designation
1	Lock out/ tag out the compressor before starting maintenance or repairs
2	Automatic condensate drain
3	Manual condensate drain
4	Lightly oil the gasket of the oil filter, screw it on and tighten by hand (approx. half a turn)
5	Warning, hot surface
6	Stop the compressor before cleaning the coolers
7	Warning, voltage
8	Switch off the voltage and wait at least 10 minutes before maintenance
9	Compressor remains pressurized for 180 seconds after switching off the voltage
10	If the rotation direction is wrong, open the isolating switch in the voltage supply line and reverse two incoming electric lines

5 Operating instructions

Initial start-up

	The operator must apply all relevant Safety precautions . Also consult section Problem solving .
--	--

	For the location of the air outlet valve and the drain connections, see sections Introduction and Condensate system .
--	---

Step	Action
1	<p>Remove the canopy panel(s) in order to get access to the internal components. Remove the red transport spacers (1) and the related bolts under the motor.</p> <div style="text-align: center;"> </div>
2	<p>Check that the electrical connections correspond to the local codes and that all wires are clamped tight to their terminals. The installation must be earthed and protected against short circuits by fuses of the inert type in all phases. An isolating switch must be installed near the compressor.</p>
3	<p>Check the voltage selecting wires at the primary side of transformer T1.</p>
4	<p>Fit air outlet valve (AV); see section Introduction for the position of the valve. Close the valve. Connect the air net to the valve.</p>
5	<p>Fit the manual condensate drain valve (Dm). Close the valve.</p>

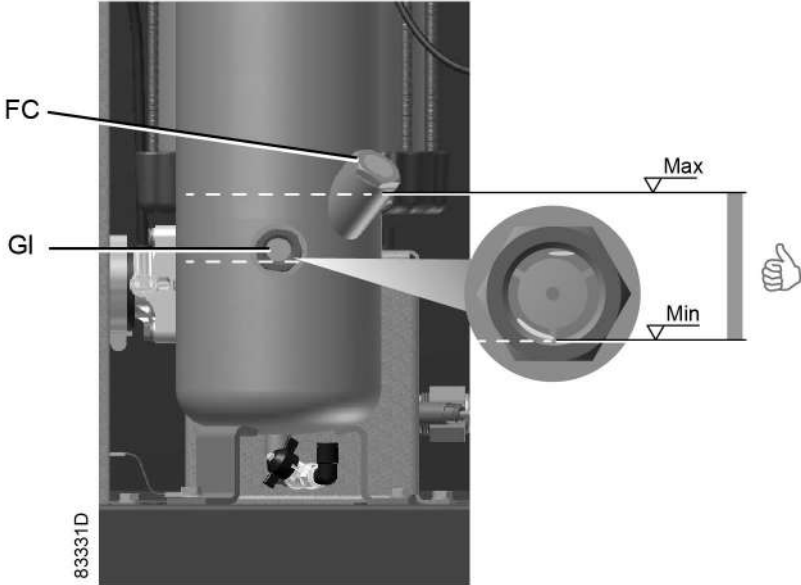
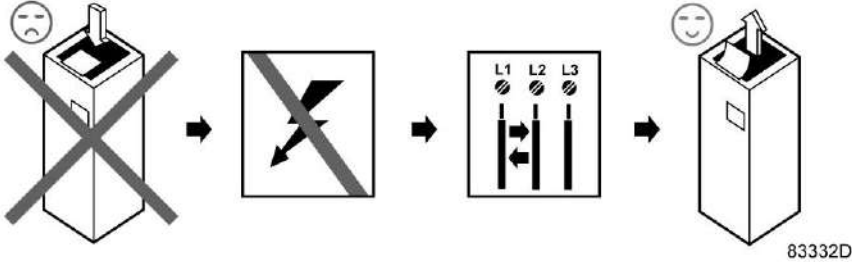
Step	Action
6	<p>Check the oil level. The oil level should reach the bottom of the oil filler neck (FC).</p>  <p>Minimum level should reach the oil sight glass (GI) when the compressor is stopped. If needed, top up the oil. Take care that no dirt drops into the oil system. Refit and tighten the filler plug (FC).</p>
7	<p>Provide labels, warning the operator that:</p> <ul style="list-style-type: none"> • The compressor may automatically restart after voltage failure (if activated, consult Atlas Copco). • The compressor is automatically controlled and may be restarted automatically. • The compressor may be remotely controlled.
8	<p>Check the rotation direction of the fan motor. For this purpose, a sheet is fixed to the top grating of the compressor.</p> <ol style="list-style-type: none"> 1. Switch on the voltage. 2. Start the compressor and stop it immediately. If the rotation direction is correct, the sheet will be blown upwards. If the sheet remains in place, the rotation direction is incorrect. 3. If the rotation direction is wrong, open the isolating switch in the voltage supply line and reverse two incoming electric lines. 4. Remove the label.  <p style="text-align: right;">83332D</p> <p style="text-align: center;"><i>Label to check correct rotation of the fan motor</i></p>
9	<p>Check the programmed settings. Consult section Programmable settings.</p>

Step	Action
10	Open the air outlet valve. Start and run the compressor for a few minutes. Check that the compressor operates normally.

Starting

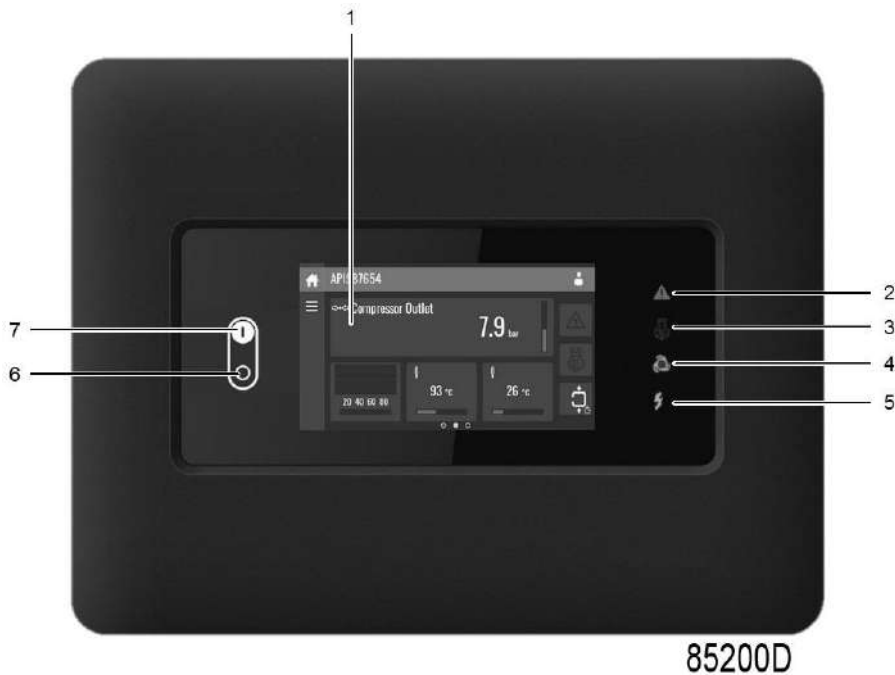

Control panel Elektronikon™ Touch

Step	Action
1	Open the air outlet valve.
2	Switch on the voltage. Check that voltage on LED (5) lights up.
3	Press start button (7) on the control panel. The compressor starts running and the automatic operation LED (4) lights up.

During operation

	Keep the panels closed during operation.
	When the motors are stopped and LED (automatic operation) is alight, the motors may start automatically.
	When the automatic operation LED is lit, the regulator is automatically controlling the compressor, i.e. loading, unloading, stopping of the motors and restarting!

Regularly check the oil level:

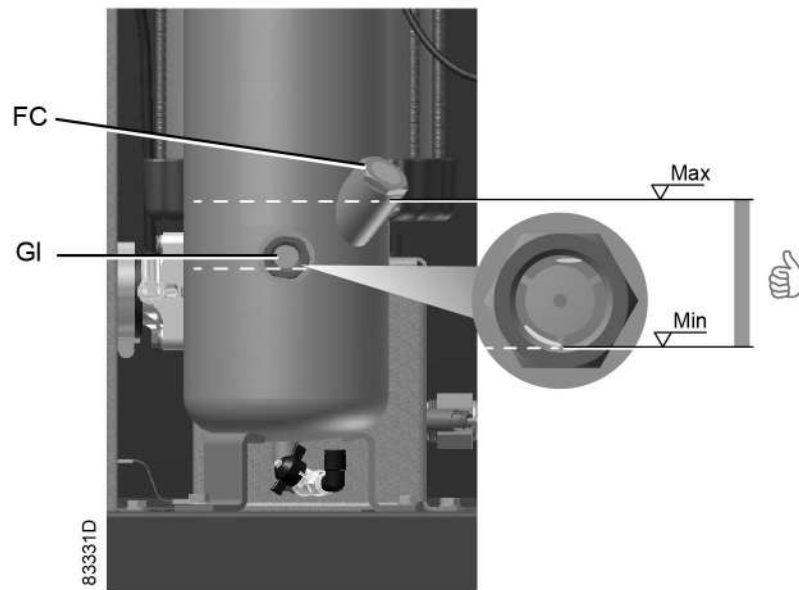

A few minutes after stopping, the oil level should reach the bottom of the oil filler neck (FC).

If the oil level is too low, wait until the compressor has depressurized. Push the emergency stop button (10) to avoid the compressor to start unexpectedly. Next, close the air outlet valve and open the manual drain valve (Dm) until the air system between oil separator/air receiver vessel and outlet valve is fully depressurized. See section [Condensate system](#) for location of the outlet valve and water drain.

Unscrew oil filler plug (FC) one turn to permit any pressure left in the system to escape. Wait a few minutes. Remove the plug and add oil until the level reaches the filler opening. Fit and tighten the plug (FC).

Unlock the emergency stop button, select the STOP icon on the display and press reset before restarting.

Regularly check that condensate is discharged during operation. See section [Condensate system](#). The amount of condensate depends on environmental and working conditions.

Regularly check the Elektronikon™ display:

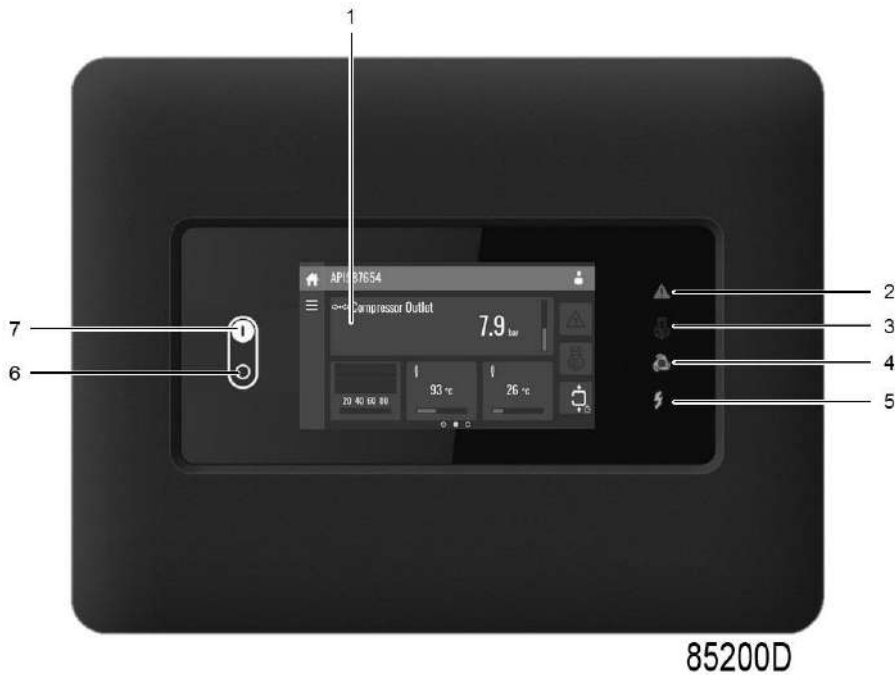

Control panel Elektronikon™ Touch controller

Check the display (1) regularly for readings and messages. The display normally shows the compressor outlet pressure, while the status of the compressor is indicated by means of a number of icons. Remedy the trouble if alarm LED (2) is lit or flashes, see section [Icons used](#). The display (1) will show a service message if a service plan interval has been exceeded or if a service level for a monitored component has been exceeded. Carry out the service actions of the indicated plans or replace the component and reset the relevant timer, see section [Service menu](#).

Stopping

Step	Action
1	Press stop button on the control panel. Automatic operation LED goes out and the compressor stops.
2	Close the air outlet valve.
3	Press the test button on top of the electronic water drain(s) to the depressurize the piping between air receiver and outlet valve, next open the manual drain valve (Dm). See section Condensate system . Switch off the voltage.

	<p>To stop the compressor in the event of an emergency, press emergency stop button. Alarm LED flashes.</p> <ul style="list-style-type: none"> • Remedy the problem cause. • Next, unlock the button by pulling it out. • Next, navigate to the Stop icon on the display by means of the navigation keys (3/4) and press the Select key. <p>Press Reset.</p> <p>Do not use emergency stop button for normal stopping!</p>
--	--

Taking out of operation

Step	Action
1	Disconnect the compressor from the mains.
2	Unscrew the oil filler plug only one turn to permit any pressure in the system to escape.
3	Shut off and depressurize the part of the air net which is connected to the outlet valve. Disconnect the compressor air outlet pipe from the air net.
4	Drain the oil.
5	Drain the condensate circuit and disconnect the condensate piping from the condensate net.

6 Maintenance

6.1 Preventive maintenance schedule

Control panel

Warning



Before carrying out any maintenance, repair work or adjustments, proceed as follows:

- Stop the compressor.
- Close the air outlet valve and open the condensate drain valve to depressurize the air system between air receiver and outlet valve.
- Press the emergency stop button (10).
- Switch off the voltage.
- Depressurize the compressor.

For detailed instructions, see section [Problem solving](#).

The operator must apply all relevant [Safety precautions](#).

Warranty - Product Liability

Use only authorised parts. Any damage or malfunction caused by the use of unauthorized parts is not covered by Warranty or Product Liability.

Service kits

For overhauling or carrying out preventive maintenance, service kits are available (see section [Service kits](#)).

Service agreements

Contact Atlas Copco to set up a tailor made service agreement. It will ensure optimum operational efficiency, minimize downtime and reduce the total life cycle cost.

General

When servicing, replace all removed O-rings and washers.

Intervals

The local Atlas Copco Customer Centre may overrule the maintenance schedule, especially the service intervals, depending on the environmental and working conditions of the compressor.

The longer interval checks must also include the shorter interval checks.

Service plans for compressors with an Elektronikon™ Touch controller

Besides the daily and 3-monthly checks, preventive service operations are specified in the schedule below.

Each plan has a programmed time interval at which all service actions belonging to that plan are to be carried out. When reaching the interval, a message will appear on the screen indicating

which service plans are to be carried out. After servicing, the intervals must be reset, see section [Service menu](#).

Preventive maintenance schedule

Daily and 3-monthly check list

Period	Operation
Daily	<p>Check oil level. If needed, top up the oil (see section Operating instructions — During operation)</p> <p>Check readings on display.</p> <p>Check that condensate is discharged by waiting for some time during operation. You can use the test button on top of the electronic water drain to check the drain function.</p>
Monthly	<p>Check that condensate is discharged when pressing the test button on top of the electronic water drain.</p>
3-monthly (1)	<p>Check coolers, clean if necessary.</p> <p>Remove the air filter element and inspect. Replace damaged or heavily contaminated elements.</p> <p>Check the filter elements of the electric cabinet. Replace if necessary.</p> <p>Check the oil return hole.</p>

Check list for compressors with dryer

Period	Operation
Daily	<p>Check that condensate is discharged by the dryer drain by waiting for some time during operation.</p> <p>You can use the test button on top of the electronic water drain to check the drain function.</p>
Monthly (1)	<p>Condenser cleaning:</p> <ul style="list-style-type: none"> • Stop the compressor, close the air outlet valve and switch off the voltage. • Remove any dirt on the condenser inlet with a vacuum cleaner. • Next, clean with an air jet in the reverse direction to normal flow. Use low pressure air. Keep the compressed air nozzle more than 30 cm away from the condenser to avoid damaging the of condenser fins. • Remove dust from inside the dryer, e.g. with a vacuum cleaner. <p>Do not use water or solvents to clean the condenser.</p>

(1): More frequently when operating in a dusty atmosphere.

Preventive Maintenance schedule programmed in the Elektronikon controller

Running hours	Operation
4000 (1)	Change oil and oil filter (except when Roto-Xtend Duty Fluid is used). Replace the air filter element. Check condition of the air intake hose between air filter and compressor element (where applicable). Check pressure and temperature readings. Check operation of cooling fans of converter. Check blow-off solenoid valve after stopping and pressing the emergency stop button. Clean coolers. Check and clean cooling fan assembly.
8000 (2)(3)	All the actions for 4000 hrs. Change oil and oil filter (when Roto-Xtend Duty Fluid is used). Replace the filter elements of the electric cabinet. Replace the oil separator element. Replace the non return valve of the scavenge line and clean the restriction nozzle. Replace the minimum pressure valve, and replace the thermostatic valve. Remove carefully. Replace the electronic drain valve. Carry out a LED/display test. Check for possible air and oil leakages. Have safety valve tested.

(1): or yearly, whichever comes first

(2): or every 2 years, whichever comes first

(3): For all 8000 hours actions, contact Atlas Copco.

The indicated oil exchange intervals are valid for standard operating conditions (see section [Reference conditions and limitations](#)) and nominal operating pressure (see section Compressor data). Exposure of the compressor to external pollutants, operation at high humidity combined with low duty cycles or operation at higher temperatures may require a shorter oil exchange interval. Contact Atlas Copco if in doubt.

Oils

In order to achieve the best machine performance and guarantee the reliability, it is required to use genuine Atlas Copco Lubricants. Their tailor made formulation is the result of years of field experience, research and in-house development. Consult the Spare Parts list for part number information.

	Avoid mixing lubricants of different brands or types as they may not be compatible and the oil mix may have inferior properties. A label, indicating the type of oil filled ex factory is stuck on the air receiver/oil tank.
---	---

Relation between operating conditions and duty type

Ambient temperature	Humid	Dust	Duty type
Below 30 °C (86 °F)	No	No	Mild
Below 30 °C (86 °F)	Yes	No	Mild
Below 30 °C (86 °F)	No	Yes	Mild
Below 30 °C (86 °F)	Yes	Yes	Demanding
Between 30 °C (86 °F) and 40 °C (104 °F)	No	No	Demanding

Ambient temperature	Humid	Dust	Duty type
Between 30 °C (86 °F) and 40 °C (104 °F)	Yes	No	Demanding
Between 30 °C (86 °F) and 40 °C (104 °F)	No	Yes	Demanding
Between 30 °C (86 °F) and 40 °C (104 °F)	Yes	Yes	Extreme
Above 40 °C (104 °F)	-	-	Extreme

Exchange interval for Roto-Inject Fluid Ndurance

Ambient temperature	Element outlet temperature	Exchange interval *	Maximum time interval *
up to 30°C (86°F)	up to 95°C (203°F)	4000	1 year
from 30°C (86°F) up to 35°C (95°F) (see note)	from 95°C (203°F) up to 100°C (212°F)	3000	1 year
from 35°C (95°F) up to 40°C (104°F) (see note)	from 100°C (212°F) up to 105°C (221°F)	2000	1 year
above 40°C (104°F)	above 105°C (221°F)	use Roto Synthetic Fluid XTEND DUTY	

Note: the presence of dust and/or high humidity may require a shorter exchange interval. Consult Atlas Copco.

Exchange interval for Roto Synthetic Fluid Ultra

Ambient temperature	Element outlet temperature	Exchange interval *	Maximum time interval *
up to 35°C (95°F)	up to 100°C (212°F)	6000	2 years
from 35°C (95°F) up to 40°C (104°F) (see note)	from 100°C (212°F) up to 105°C (221°F)	4000	2 years
from 40°C (104°F) up to 45°C (113°F) (see note)	from 105°C (221°F) up to 110°C (230°F)	2000	2 years

Exchange interval for Roto Synthetic Fluid Xtend-Duty

Ambient temperature	Element outlet temperature	Exchange interval *	Maximum time interval *
up to 35°C (95°F)	up to 100°C (212°F)	8000	2 years
from 35°C (95°F) up to 40°C (104°F) (see note)	from 100°C (212°F) up to 105°C (221°F)	6000	2 years
above 40°C (104°F)	above 105°C (221°F)	5000	2 years

Note: the presence of dust and/or high humidity may require a shorter exchange interval. Consult Atlas Copco.

Note: the presence of dust and/or high humidity may require a shorter exchange interval. Consult Atlas Copco.

* Whichever comes first.

Important



- Always consult your supplier if a timer setting has to be changed.
- For the change interval of oil and oil filter in extreme conditions of temperature, humidity or cooling air, consult your supplier.
- Any leakage should be attended to immediately. Damaged hoses or flexible joints must be replaced.
- For change of oil contact Atlas Copco for the correct procedure.
- For changing of one type of oil to another type of oil consult Atlas Copco for the correct procedure as this is not allowed in some conditions.

6.2 Oil specifications

It is strongly recommended to use genuine Atlas Copco Lubricants. They are the result of years of field experience and research. See section Preventive maintenance schedule for the advised replacement intervals and consult your Spare Parts list for part number information.



Avoid mixing lubricants of different brands or types as they may not be compatible and the oil mix may have inferior properties. A label, indicating the type of oil filled ex factory, is stuck on the air receiver/oil tank.

Roto-Inject Fluid NDURANCE

Atlas Copco's Roto-Inject Fluid NDURANCE is a premium mineral oil based 4000 hours lubricant, specially developed for use in single stage oil injected screw compressors running in mild conditions. Its specific formulation keeps the compressor in excellent condition. Roto-Inject Fluid NDURANCE can be used for compressors operating at ambient temperatures between 0 °C (32 °F) and 40 °C (104 °F). If the compressor is regularly operating in ambient temperatures above 35 °C (95 °F), it is recommended to use Roto Synthetic Fluid ULTRA or Roto Synthetic Fluid XTEND DUTY.

Roto Synthetic Fluid ULTRA

Roto Synthetic Fluid ULTRA is a synthetic oil based 4000 hours lubricant, specially developed for use in single stage oil injected screw compressors running in demanding conditions. Roto Synthetic Fluid ULTRA can be used for compressors operating at ambient temperatures between 0 °C (32 °F) and 45 °C (113 °F). For more extreme conditions, or when longer oil life is required, it is recommended to use Roto Synthetic Fluid XTEND DUTY.

Roto Synthetic Fluid XTEND DUTY

Atlas Copco's Roto Synthetic Fluid XTEND DUTY is a high quality synthetic 8000 hours lubricant for oil injected screw compressors which keeps the compressor in excellent condition. Because of its excellent oxidation stability, Roto Synthetic Fluid XTEND DUTY can be used for compressors operating at ambient temperatures between 0 °C (32 °F) and 46 °C (115 °F). Roto Synthetic Fluid XTEND DUTY is the standard lubricant for oil injected screw compressors equipped with freeze protection or Energy Recovery.

If the compressor is regularly operating in ambient temperatures above 40 °C (104 °F), oil lifetime is reduced (see table oil lifetime [Preventive maintenance schedule](#)).

Roto-Foodgrade Fluid

Special oil, delivered as an option.

Atlas Copco's Roto-Foodgrade Fluid is a unique high quality synthetic lubricant, specially created for oil injected screw compressors that provide air for the food industry. This lubricant keeps the compressor in excellent condition. Roto-Foodgrade Fluid can be used for compressors operating at ambient temperatures between 0 °C (32 °F) and 40 °C (104 °F).

Roto-Foodgrade Fluid has all required certification for use in food & beverage industry: like NSFH1, Kosher, Halal and Allergen Free approvals.

If the compressor is regularly operating in ambient temperatures above 35 °C (95 °F), oil lifetime is reduced (see table oil lifetime [Preventive maintenance schedule](#)).

6.3 Drive motor

Bearing maintenance

The motor bearing is lubricated by oil injection. Re-greasing is not necessary.

6.4 Air filter

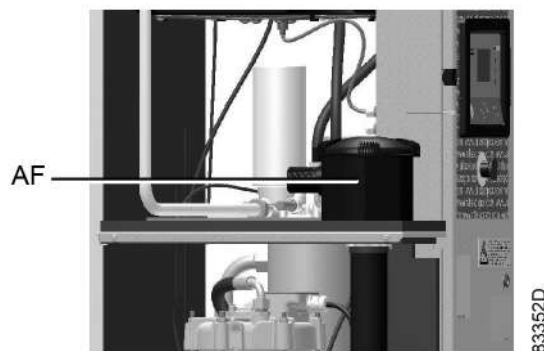

Location of air filter

Procedure

1. Stop the compressor. Switch off the voltage.
2. Remove the cover of the air filter (AF) by turning it anti clockwise. Remove the filter element.
3. Fit the new element and the cover.
4. Reset the air filter service warning.

6.5 Oil, oil filter and oil separator change

Warning

	<p>The operator must apply all relevant Safety precautions. Always drain the compressor oil at all drain points. Used oil left in the compressor can contaminate the oil system and can shorten the lifetime of the new oil. Never mix lubricants of different brands or types as they may not be compatible and the oil mix will have inferior properties. A label, indicating the type of oil filled ex factory, is stuck on the air receiver/oil tank.</p>
--	---

Procedure

1. Run the compressor until warm and stop the compressor.
 - Close the air outlet valve and switch off the voltage.
 - Wait 3 minutes for the compressor to depressurise the vessel.
 - Open the condensate drain valve to depressurise the cooler. (see condensate system) and close again.
 - Unscrew the oil filler plug (FC) just one turn to permit any remaining pressure in the system to escape.
 - Cover the duct of the heat sink on the electric cabinet.
2. Remove the vent plug (VP) of the oil cooler.

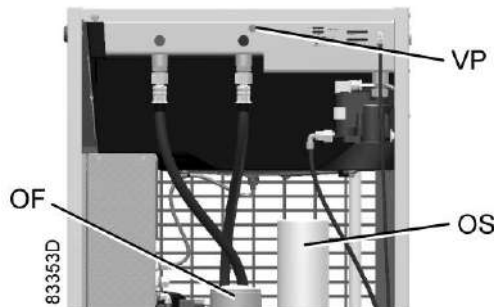

Vent plug, oil cooler Workplace

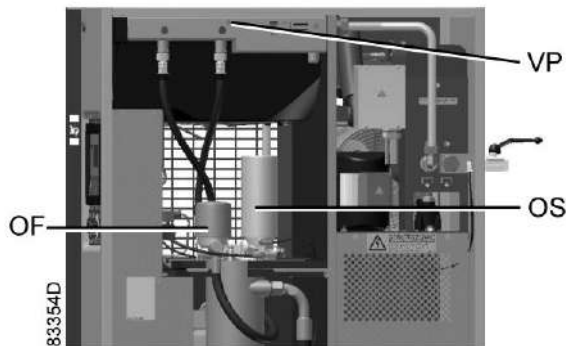

Vent plug, oil cooler Workplace Full-Feature

3. Open the oil drain valve (Do).

- Hold the oil drain hose (1) downward to drain the oil.



- Disconnect the air hose (2) at the top on the vessel.
 - Move the hose downward to drain the oil from the element.
 - Remove the oil filter (OF). **Be aware that this filter has a left thread connection.**
 - Remove the oil separator (OS). **Be aware that this filter has a left thread connection.**
 - Collect the oil in a collector and deliver it to the local collection service. Refit the vent plugs after draining.
- Close the oil drain valve (Do).
 - Refit the drain hose at the top of the air receiver.
- Clean the seat on the manifold. Lubricate the gasket of the new oil filter and screw it into place. Tighten firmly by hand.
 - Clean the seat on the manifold. Lubricate the gasket of the new oil separator and screw it into place. Tighten firmly by hand.
- Remove filler plug (FC).
 - Fill the air receiver with oil until the level reaches the filler neck.

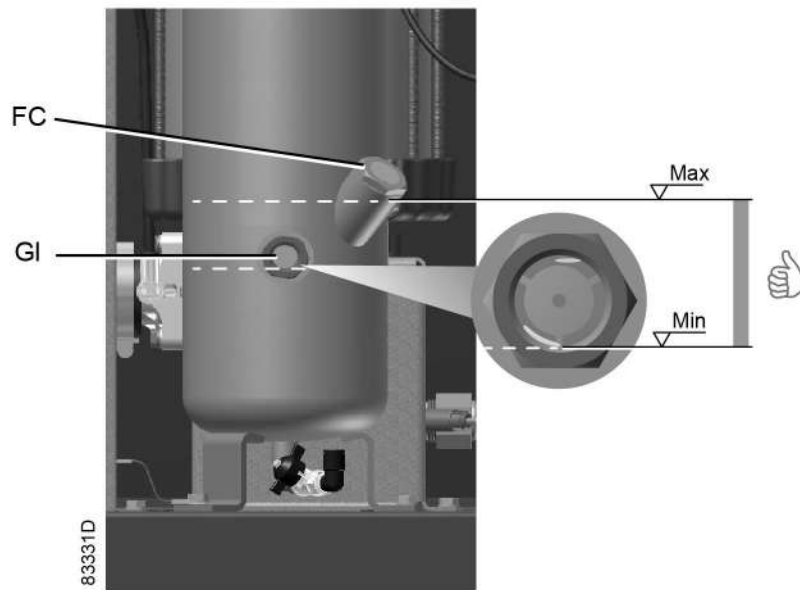

- Take care that no dirt drops into the system. Refit and tighten filler plug (FC).
8. Run the compressor loaded for a few minutes. Stop the compressor.
 9. Close the air outlet valve and switch off the voltage.
 - Wait 3 minutes for the compressor to depressurize the vessel.
 - Open the condensate drain valve (Dm) to depressurize the cooler. (see [Condensate system](#)) and close again.
 - Unscrew the oil filler plug (FC) just one turn to permit any remaining pressure in the system to escape.
 10. Fill the air receiver (AR) with oil until the level reaches the filler neck. (see [Operating instructions / During operation](#))
 - Refit and tighten filler plug (FC).
- When the oil level is too low, go back to step 7.

6.6 Coolers

General

Keep the coolers clean to maintain their efficiency.

Procedure

- Stop the compressor, close the air outlet valve and switch off the voltage.
- Cover all parts underneath the cooler.
- Remove the service plate (1) at the fan compartment.



- Remove dirt from the coolers with a fibre brush. Brush in the direction of the cooling fins. Remove dirt from the fan with a fibre brush.
- Clean with an air jet in the reverse direction to normal flow.
- If it is necessary to wash the coolers with a cleaning agent, consult Atlas Copco.



After maintenance on the fan and on the coolers:
Remove the material that was used as cover.

- Mount the service plate (1) at the fan compartment.

Procedure for compressors with dryer.

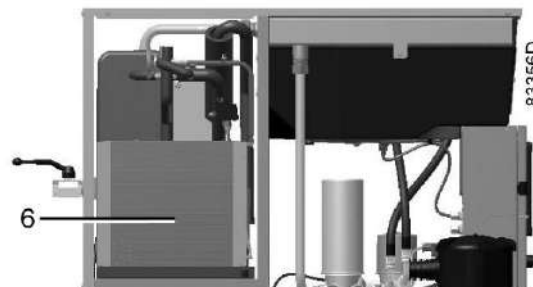

Location of the condenser of the dryer

- Remove dirt on the inlet of the condenser (6) with a fibre brush.
- Clean with an air jet in the reverse direction to normal flow.
- Clean the condenser area with a fibre brush.

6.7 Dryer maintenance instructions

Safety precautions

Refrigeration dryers of ID type contain refrigerant HFC.

When handling refrigerant, all applicable [safety precautions](#) must be observed. Please be specifically aware of the following points:

- Contact of refrigerant with the skin will cause freezing. Special gloves must be worn. If contacted with the skin, the skin should be rinsed with water. On no account may clothing be removed.
- Fluid refrigerant will also cause freezing of the eyes; always wear safety glasses.

- Refrigerant is harmful. Do not inhale refrigerant vapours. Check that the working area is adequately ventilated.

Be aware that certain components such as the refrigerant compressor and the discharge pipe can become quite hot (up to 110 °C - 230 °F). Therefore, wait until the dryer has cooled down before removing the panels.

Before starting any maintenance or repair work, switch off the voltage and close the air inlet and outlet valves.

Local legislation

Local legislation may stipulate that:

- Work on the refrigerant circuit of the cooling dryer or on any equipment which influences its function must be undertaken by an authorised control body.
- The installation should be checked once a year by an authorised control body.

6.8 Safety valves

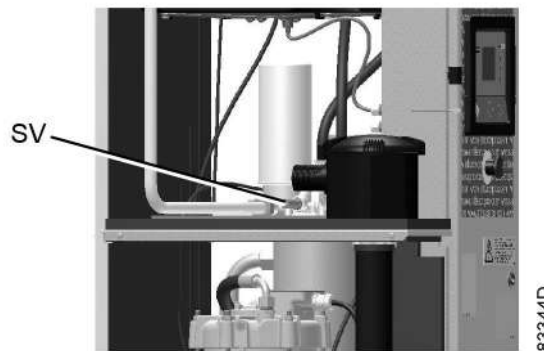

Location of safety valve

Testing

	The safety valve (SV) test can only be performed by authorized personnel and is protected by a security code. Refer to Elektronikon™ Touch controller.
--	--

If the safety valve does not open at the set pressure stamped on the valve, it needs to be replaced.

Warning

	No adjustments are allowed. Never run the compressor without safety valve.
--	--

6.9 Service kits

Service kits

For overhauling and for preventive maintenance, a wide range of service kits is available. Service kits comprise all parts required for servicing the component and offer the benefits of genuine Atlas Copco parts while keeping the maintenance budget low.

Also a full range of extensively tested lubricants, suitable for your specific needs is available to keep the compressor in excellent condition.

Consult the Spare Parts List for part numbers.

6.10 Storage after installation

Procedure

Run the compressor regularly, e.g. twice a week, until warm.



If the compressor is going to be stored without running from time to time, protective measures must be taken. Consult your supplier.

7 Problem solving

Warning

	<p>Before carrying out any maintenance, repair work or adjustment, stop compressor, wait 3 minutes and close the air outlet valve.</p> <p>Press the test button on top of the electronic water drain until the air system between the air receiver and outlet valve is fully depressurized.</p> <p>Press the emergency stop button and switch off the voltage.</p> <p>Depressurise the compressor by opening the oil filler plug one turn.</p> <p>For location of components, see sections:</p> <ul style="list-style-type: none"> • Introduction. • Condensate system. • Operation instructions • Maintenance.
	Open and lock the isolating switch.
	<p>Lock the air outlet valve during maintenance or repair as follows:</p> <ul style="list-style-type: none"> • Close the valve. • Remove the screw fixing the handle with the wrench delivered with the compressor. • Lift the handle and turn it until the slot of the handle fits over the blocking edge on the valve body. • Fit the screw.
	The operator must apply all relevant Safety precautions .

Before electrical maintenance

	<p>Wait for at least 10 minutes before starting any electrical repairs as dangerous high voltage remains on the capacitors of the start and speed regulation unit during some minutes after switching off the voltage.</p> <p>On VSD+ units, wait for at least 10 minutes before starting any electrical repairs as dangerous high voltage remains on the capacitors of the start and speed regulation unit during some minutes after switching off the voltage.</p>
---	--

Faults and remedies, compressor

If the alarm LED is lit or flashes, consult section [Service menu](#).

Condition	Fault	Remedy
Condensate is not discharged from condensate separator during loading	Discharge flexible clogged	Check and correct as necessary.

Condition	Fault	Remedy
Compressor air output or pressure below normal	Air consumption exceeds air delivery of compressor	Check equipment connected.
	Choked air filter element	Replace filter element.
	Solenoid valve malfunctioning	Replace valve.
	Oil separator clogged	Have element replaced.

Condition	Fault	Remedy
	Air leakage	Have leaks repaired.
	Safety valve leaking	Have valve replaced.
	Compressor element out of order	Consult Atlas Copco.

Condition	Fault	Remedy
Safety valve blows	Minimum pressure valve malfunctioning	Check and have defective parts replaced.
	Oil separator clogged	Have element replaced.
	Safety valve out of order	Have valve checked. Replace if necessary.
	On Full-Feature compressors, dryer piping clogged due to formation of ice	Have system checked by Atlas Copco.

Condition	Fault	Remedy
Compressor element outlet temperature or delivery air temperature above normal	Oil level too low	Check and correct, see Operation instructions / During operation
	On air-cooled compressors, insufficient cooling air or cooling air temperature or relative humidity is too high	Check for cooling air restriction or improve ventilation of the compressor room. Avoid recirculating of cooling air. If installed, check capacity of compressor room fan.
	Oil cooler clogged	Clean cooler.
	By-pass valve malfunctioning	Have valve tested.
	Air cooler clogged	Clean cooler.
	Compressor element out of order	Consult Atlas Copco.
	Degraded oil	Check service intervals, see Preventive maintenance schedule .

Condition	Fault	Remedy
Low Load Alarm triggered: Compressor running with too low oil temperature over a longer period of time	Solenoid valve malfunctioning	Replace valve.
	Extreme low usage of compressor	Increase loading profile (longer and/or more load cycles required). If not possible, consult Atlas Copco.

Converter fault codes

If a problem is detected by the converter, a specific code will appear on the Elektronikon display. Below table lists the most important error codes. If another code appears, please contact Atlas Copco.

Tap the Alarm button to enter the status of the alarm.



Typical display when compressor is stopped by shutdown

Tap the alarm to display the Main Motor Converter Alarm.



(1)	Main Motor Converter Alarm
-----	----------------------------

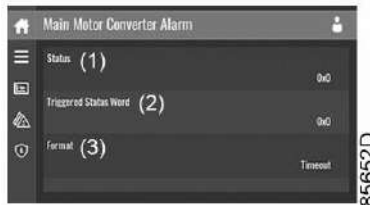

(1)	Status
(2)	Triggered Status Word
(3)	Format

Fault code	Cause	Actions
1	Overcurrent	Contact Atlas Copco.
	Ground fault	Contact Atlas Copco.
2	Too high voltage. The voltage on the converter is above the specifications.	Check the supply voltage. Contact Atlas Copco.
3	Too low voltage. The voltage on the converter is below the specifications. Power quality faults	Check the supply voltage. Contact Atlas Copco.
		Check for loose wiring/wiring errors. Check supply voltage during start up. Check fuses transformer (200V, 230V, 500V and 575V units only)

Fault code	Cause	Actions
4	Drive overload.	Contact Atlas Copco.
8	Converter overheating (heat sink)	Check the ambient temperature. Check the cubicle cooling. Check airflow around drive. Check cooling fan and cooler contamination. Contact Atlas Copco.
256	Hardware fault	Contact Atlas Copco.
512	Motor overload	Contact Atlas Copco.
	Drive overload	Contact Atlas Copco.
	Over-torque detection	Contact Atlas Copco.
	Under-torque detection	Contact Atlas Copco.
1024	Over-speed	Contact Atlas Copco.
	Safe torque off	Check for loose wiring at inverter. Push emergency stop button. Check temperature switch.
8192	Output phase loss	Contact Atlas Copco.
	Input phase loss	Check supply voltage. Check for loose wiring/wiring errors. Check supply voltage during start-up. Check fuses transformer (200V, 230V, 500V and 575V units only).
16384	Communication error	Contact Atlas Copco.
TIME-OUT	Time-out communication error between Elektronikon and Inverter	Contact Atlas Copco.

Faults and remedies, dryer

For all references hereafter, consult section [Air dryer](#).

Condition	Fault	Remedy
Pressure dew point too high	Air inlet temperature too high	Check and correct; if necessary, clean the aftercooler of the compressor.
	Ambient temperature too high	Check and correct; if necessary, draw cooling air via a duct from a cooler place or relocate the compressor.
	Shortage of refrigerant	Have circuit checked for leaks and recharged.
	Refrigerant compressor does not run	See below.
	Evaporator pressure too high	See below.
	Condenser pressure too high	See below.
Condenser pressure too high or too low	Fan control switch out of order	Replace.
	Fan blades or fan motor out of order	Have checked fan/fan motor, if necessary replace.

Condition	Fault	Remedy
	Ambient temperature too high	Check and correct; if necessary, draw cooling air via a duct from a cooler place or relocate the compressor.
	Condenser externally clogged	Clean condenser.
Compressor stops or does not start	Electric power supply to compressor is interrupted	Check and correct as necessary.
	Thermal protection of refrigerant compressor motor has tripped	Motor will restart when motor windings have cooled down.
Electronic condensate drain remains inoperative	Electronic drain system clogged	Have system inspected. Clean the filter of the automatic drain by opening the manual drain valve. Check functioning of the drain by pushing the test button.
Condensate trap continuously discharges air and water	Automatic drain out of order	Have system checked. If necessary, replace the automatic drain.
Evaporator pressure is too high or too low at unload	Hot gas bypass valve incorrectly set or out of order	Have hot gas bypass valve adjusted.
	Condenser pressure too high or too low	See above.
	Shortage of refrigerant	Have circuit checked for leaks and recharged if necessary.

8 Technical data

8.1 Readings on display



85199D

Elektronikon™ Touch controller

Important



The readings mentioned below are valid under the reference conditions (see section [Reference conditions and limitations](#)).

Reference	Reading
Air outlet pressure	Depends on the setpoint (desired net pressure).
Compressor element outlet temperature	Approx. 80 °C (176 °F) (ambient temperature 20 °C + 60 °C)
Dewpoint temperature (on units with integrated dryer)	Approx. 4 °C (39 °F).

8.2 Electric cable size and fuses

Important



- The voltage on the compressor terminals must not deviate more than 10% of the nominal voltage.
It is however highly recommended to keep the voltage drop over the supply cables at nominal current below 5% of the nominal voltage (IEC 60204-1).
- If cables are grouped together with other power cables, it may be necessary to use cables of a larger size than those calculated for the standard operating conditions.
- Use the original cable entry. See section [Dimension drawings](#).
- **To preserve the IP protection degree of the electric cubicle and to protect its components from dust from the environment, it is mandatory to use a proper cable gland when connecting the supply cable to the compressor.**
- Local regulations remain applicable if they are stricter than the values proposed below.
- **Caution:**
 - Always double-check the fuse size versus the calculated cable size. If required, reduce fuse size or enlarge cable size.
 - Cable length should not exceed the maximum length according to IEC60204 table 10.

Leakage breaker (optional)

If the installation requires a leakage breaker, always use an all current sensitive leakage breaker, RCM or RCD Type B (according to IEC/EN 60755) with a sufficient trip level.

Currents and fuses

Compressor type				I _{max} (1)	Fuse (1)	Fuse (1)	I _{max} (2)	Fuse (2)	Fuse (2)
					gL/gG	aR		gL/gG	aR
GA 7 VSD+	IEC	50 Hz	200 V	36.8 A	40 A	-	39.9 A	50 A	-
GA 7 VSD+	IEC	50 Hz	230 V	36.9 A	40 A	-	40.0 A	50 A	-
GA 7 VSD+	IEC	50 Hz	400 V	18.4 A	-	20 A	20.1 A	-	25 A
GA 7 VSD+	IEC	60 Hz	200 V	36.8 A	40 A	-	39.9 A	50 A	-
GA 7 VSD+	IEC	60 Hz	230 V	36.9 A	40 A	-	40.0 A	50 A	-
GA 7 VSD+	IEC	60 Hz	380 V	18.5 A	-	20 A	20.1 A	-	25 A
GA 7 VSD+	IEC	60 Hz	460 V	18.5 A	-	20 A	20.0 A	-	25 A

Compressor type				I _{max} (1)	Fuse (1)	Fuse (1)	I _{max} (2)	Fuse (2)	Fuse (2)
					gL/gG	aR		gL/gG	aR
GA 11 VSD+	IEC	50 Hz	200 V	48.8 A	63 A	-	51.9 A	63 A	-
GA 11 VSD+	IEC	50 Hz	230 V	48.9 A	63 A	-	52.0 A	63 A	-
GA 11 VSD+	IEC	50 Hz	400 V	24.4 A	-	25 A	26.0 A	-	32 A
GA 11 VSD+	IEC	60 Hz	200 V	48.8 A	63 A	-	51.9 A	63 A	-
GA 11 VSD+	IEC	60 Hz	230 V	48.9 A	63 A	-	52.0 A	63 A	-
GA 11 VSD+	IEC	60 Hz	380 V	24.5 A	-	25 A	26.1 A	-	32 A

Compressor type				I _{max} (1)	Fuse (1)	Fuse (1)	I _{max} (2)	Fuse (2)	Fuse (2)
					gL/gG	aR		gL/gG	aR
GA 11 VSD+	IEC	60 Hz	460 V	24.5 A	-	25 A	26.0 A	-	32 A

Compressor type				I _{max} (1)	Fuse (1)	Fuse (1)	I _{max} (2)	Fuse (2)	Fuse (2)
					gL/gG	aR		gL/gG	aR
GA 15 VSD+	IEC	50 Hz	200 V	62.8 A	80 A	-	68.0 A	80 A	-
GA 15 VSD+	IEC	50 Hz	230 V	62.9 A	80 A	-	68.1 A	80 A	-
GA 15 VSD+	IEC	50 Hz	400 V	31.4 A	-	32 A	34.0 A	-	40 A
GA 15 VSD+	IEC	60 Hz	200 V	62.8 A	80 A	-	68.0 A	80 A	-
GA 15 VSD+	IEC	60 Hz	230 V	62.9 A	80 A	-	68.1 A	80 A	-
GA 15 VSD+	IEC	60 Hz	380 V	31.5 A	-	32 A	34.1 A	-	40 A
GA 15 VSD+	IEC	60 Hz	460 V	31.5 A	-	32 A	34.0 A	-	40 A

I_{max} (1): maximum current in the supply lines at maximum load and nominal voltage for compressors without integrated dryer.

Fuse (1): maximum fuse size to protect the supply lines in case of compressors without integrated dryer.

I_{max} (2): maximum current in the supply lines at maximum load and nominal voltage for compressors with integrated dryer.

Fuse (2): maximum fuse size to protect the supply lines in case of compressors with integrated dryer.

Compressors without built-in transformer require quick fuses to protect the frequency converter. Compressors with transformer have slow fuses in the supply lines, but quick fuses in the secondary of the transformer.

Setting of circuit breakers

Q1	1 A
Q15 (where applicable)	0.5 A 0.6 A (CHN)

Fuse calculations for IEC are done according to 60364-4-43 electrical installations of buildings, part 4: protection for safety- section 43: protection against overcurrent. Fuse sizes are calculated in order to protect the cable against short circuit.

Earthing

The earthing cable connected to the compressor (PE) should be minimum 10 mm² (according to EN 60204-1 section 828).

Cable sizing according IEC

The tables below indicate the current carrying capacities of cables for 3 commonly used installation methods, calculated according to standard 60364-5-52 - electrical installations of

buildings part 5 - selection and erection equipment and section 52 - current carrying capacities in wiring systems.

The allowed currents are valid for PVC insulated cables with three loaded copper conductors (maximum conductor temperature 70 °C).

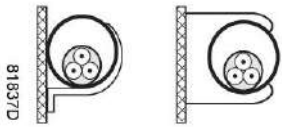

Installation method B2 according table B.52.1.
Multi-core cable in conduit on a wooden wall

Maximum allowed current in function of the ambient temperature for installation method B2

Cable section	Ambient temperature				
	30 °C	40 °C	45 °C	50 °C	55 °C
4 mm ²	< 27 A	< 23 A	< 21 A	< 19 A	< 16 A
6 mm ²	< 34 A	< 30 A	< 27 A	< 24 A	< 21 A
10 mm ²	< 46 A	< 40 A	< 36 A	< 33 A	< 28 A
16 mm ²	< 62 A	< 54 A	< 49 A	< 44 A	< 38 A
25 mm ²	< 80 A	< 70 A	< 63 A	< 57 A	< 49 A
35 mm ²	< 99 A	< 86 A	< 78 A	< 70 A	< 60 A
50 mm ²	< 118 A	< 103 A	< 93 A	< 84 A	< 72 A
70 mm ²	< 149 A	< 130 A	< 118 A	< 106 A	< 91 A
95 mm ²	< 179 A	< 156 A	< 141 A	< 127 A	< 109 A
120 mm ²	< 206 A	< 179 A	< 163 A	< 146 A	< 126 A

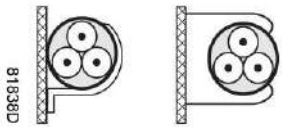

Installation method C according table B.52.1.
Single-core or multi-core cable on a wooden wall

Maximum allowed current in function of the ambient temperature for installation method C

Cable section	Ambient temperature				
	30 °C	40 °C	45 °C	50 °C	55 °C
4 mm ²	< 32 A	< 28 A	< 25 A	< 23 A	< 20 A
6 mm ²	< 41 A	< 36 A	< 32 A	< 29 A	< 25 A
10 mm ²	< 57 A	< 50 A	< 45 A	< 40 A	< 35 A
16 mm ²	< 76 A	< 66 A	< 60 A	< 54 A	< 46 A
25 mm ²	< 96 A	< 84 A	< 76 A	< 68 A	< 59 A
35 mm ²	< 119 A	< 104 A	< 94 A	< 84 A	< 73 A
50 mm ²	< 144 A	< 125 A	< 114 A	< 102 A	< 88 A
70 mm ²	< 184 A	< 160 A	< 145 A	< 131 A	< 112 A
95 mm ²	< 223 A	< 194 A	< 176 A	< 158 A	< 136 A

Cable section	Ambient temperature				
	30 °C	40 °C	45 °C	50 °C	55 °C
120 mm ²	< 259 A	< 225 A	< 205 A	< 184 A	< 158 A

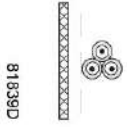
	Installation method F according table B.52.1. Single-core cables, touching in free air Clearance to wall not less than one cable diameter
---	---

Maximum allowed current in function of the ambient temperature for installation method F

Cable section	Ambient temperature				
	30 °C	40 °C	45 °C	50 °C	55 °C
25 mm ²	< 110 A	< 96 A	< 87 A	< 78 A	< 67 A
35 mm ²	< 137 A	< 119 A	< 108 A	< 97 A	< 84 A
50 mm ²	< 167 A	< 145 A	< 132 A	< 119 A	< 102 A
70 mm ²	< 216 A	< 188 A	< 171 A	< 153 A	< 132 A
95 mm ²	< 264 A	< 230 A	< 209 A	< 187 A	< 161 A
120 mm ²	< 308 A	< 268 A	< 243 A	< 219 A	< 188 A

Calculation method for IEC:

- Single supply cables (3 phases + PE - configuration (1)):
 - Add 10 % to the total compressor current ($I_{tot}Pack$ or $I_{tot}FF$ from the tables)
 - Install the prescribed fuse on each cable
- Parallel supply cable (2 x 3 phases + PE - configuration (2)):
 - Add 10 % to the total compressor current ($I_{tot}Pack$ or $I_{tot}FF$ from the tables) and divide by 2
 - Multiply the ampacity of the cables with 0.8 (see table A.52.17 (52-E1))
 - Install fuses of half the size of the recommended maximum fuse size on each cable.
- When using 2 x 3 phases + PE as in (3):
 - Add 10 % to the total compressor current ($I_{tot}Pack$ or $I_{tot}FF$ from the tables) and divide by $\sqrt{3}$
 - Multiply the ampacity of the cables with 0.8 (see table A.52.17 (52-E1))
 - Fuse size: the recommended maximum fuse size divided by $\sqrt{3}$ on each cable.
- Size of the PE cable:
 - For supply cables up to 35 mm²: same size as supply cables
 - For supply cables larger than 35 mm²: half the size of the supply wires

Always check the voltage drop over the cable (less than 5 % of the nominal voltage is recommended).

Example: $I_{tot} = 89$ A, maximum ambient temperature is 45 °C, recommended fuse = 100 A

- Single supply cables (3 phases + PE - configuration (1)):
 - $I = 89$ A + 10 % = $89 \times 1.1 = 97.9$ A
 - The table for B2 and ambient temperature = 45 °C allows a maximum current of 93 A for a 50 mm² cable. For a cable of 70 mm², the maximum allowed current is 118 A, which is sufficient. Therefore, use a 3 x 70 mm² + 35 mm² cable.

If method C is used, 50 mm² is sufficient. (35 mm² for method F) => cable 3 x 50 mm² + 25 mm².

- Parallel supply cable (2 x 3 phases + PE - configuration (2)):
 - $I = (89 \text{ A} + 10 \%) / 2 = (89 \times 1.1) / 2 = 49 \text{ A}$
 - For a cable of 25 mm², B2 at 45 °C, the maximum current is 63 A x 0.8 = 50.4 A. So 2 parallel cables of 3 x 25 mm² + 25 mm² are sufficient.
 - Install 50 A fuses on each cable instead of 100 A.

8.3 Reference conditions and limitations

Reference conditions

Air inlet pressure (absolute)	bar	1
Air inlet pressure (absolute)	psi	14.5
Air inlet temperature	°C	20
Air inlet temperature	°F	68
Relative humidity	%	0
Working pressure		See section Compressor data.

Limitations

Maximum working pressure		See section Compressor data.
Minimum working pressure	bar(e)	5.5
Minimum working pressure	psig	80
Maximum air inlet temperature	°C	46
Maximum air inlet temperature	°F	115
Minimum ambient temperature	°C	0
Minimum ambient temperature	°F	32

8.4 Compressor data

Reference conditions

	All data specified below apply under reference conditions, see section Reference conditions and limitations .
---	---

Common compressor data

	Unit	
Number of compression stages		1
Temperature of the air leaving the outlet valve (approx.), Workplace	°C	30
Temperature of the air leaving the outlet valve (approx.), Workplace	°F	86

Temperature of the air leaving the outlet valve (approx.), Workplace Full-Feature	°C	30
Temperature of the air leaving the outlet valve (approx.), Workplace Full-Feature	°F	86
Refrigerant type, Workplace Full-Feature		R134a

GA 7 VSD+

Normal effective working pressure	bar(e)	5.5	7	9.5	12.5
Normal effective working pressure	psig	80	102	138	181
Maximum effective working pressure, Workplace	bar(e)	13	13	13	13
Maximum effective working pressure, Workplace	psig	189	189	189	189
Maximum effective working pressure, Workplace Full-Feature	bar(e)	12.75	12.75	12.75	12.75
Maximum effective working pressure, Workplace Full-Feature	psig	185	185	185	185
Maximum motor shaft speed	rpm	5250	5250	4500	3750
Minimum motor shaft speed	rpm	1900	1900	1900	2100

Nominal motor power	kW	7.5
Nominal motor power	hp	10
Total amount of refrigerant, Workplace Full-Feature	kg	0.4
Total amount of refrigerant, Workplace Full-Feature	lb	0.88
Oil capacity	l	6.5
Oil capacity	US gal	1.72
Oil capacity	Imp. gal	1.43
Oil capacity	cu. ft.	0.23
Sound pressure level (according to ISO 2151 (2004))	dB(A)	62

GA 11 VSD+

Normal effective working pressure	bar(e)	5.5	7	9.5	12.5
Normal effective working pressure	psig	80	102	138	181
Maximum effective working pressure, Workplace	bar(e)	13	13	13	13
Maximum effective working pressure, Workplace	psig	189	189	189	189
Maximum effective working pressure, Workplace Full-Feature	bar(e)	12.75	12.75	12.75	12.75
Maximum effective working pressure, Workplace Full-Feature	psig	185	185	185	185
Maximum motor shaft speed	rpm	7700	7700	6500	5750

Minimum motor shaft speed	rpm	1900	1900	1900	2100
---------------------------	-----	------	------	------	------

Nominal motor power		kW	11
Nominal motor power		hp	14.75
Total amount of refrigerant, Workplace Full-Feature		kg	0.4
Total amount of refrigerant, Workplace Full-Feature		lb	0.88
Oil capacity		l	7.1
Oil capacity		US gal	1.88
Oil capacity		Imp. gal	1.56
Oil capacity		cu. ft.	0.25
Sound pressure level (according to ISO 2151 (2004))		dB(A)	63

GA 15 VSD+

Normal effective working pressure	bar(e)	5.5	7	9.5	12.5
Normal effective working pressure	psig	80	102	138	181
Maximum effective working pressure, Workplace	bar(e)	13	13	13	13
Maximum effective working pressure, Workplace	psig	189	189	189	189
Maximum effective working pressure, Workplace Full-Feature	bar(e)	12.75	12.75	12.75	12.75
Maximum effective working pressure, Workplace Full-Feature	psig	185	185	185	185
Maximum motor shaft speed	rpm	10000	10000	8500	6750
Minimum motor shaft speed	rpm	1900	1900	1900	2100

Nominal motor power		kW	15
Nominal motor power		hp	20.1
Total amount of refrigerant, Workplace Full-Feature		kg	0.5
Total amount of refrigerant, Workplace Full-Feature		lb	1.10
Oil capacity		l	7.8
Oil capacity		US gal	2.06
Oil capacity		Imp. gal	1.72
Oil capacity		cu. ft.	0.28
Sound pressure level (according to ISO 2151 (2004))		dB(A)	64

Fan data

Model	Static pressure head	Flow	Maximum absorbed power
GA 7 VSD+, GA11 VSD+, GA 15 VSD+	80 Pa (0.32 in WC)	2500 m ³ /h (1500 cfm)	200 W

8.5 Technical data controller

General

Supply voltage	24 V AC /16 VA 50/60Hz (+40%/-30%) 24 V DC/0.7 A
Type of protection	IP54 (front) IP21 (back)
<ul style="list-style-type: none"> Operating temperature range Storage temperature range 	<ul style="list-style-type: none"> -10°C.....+60°C (14 °F140 °F) -30°C.....+70°C (-22 °F158 °F)
Permissible humidity	Relative humidity 90% No condensation
Mounting	Cabinet door

Digital outputs

Number of outputs	9
Type	Relay (voltage free contacts)
Rated voltage AC	250 V AC / 10 A max.
Rated voltage DC	30 V DC / 10 A max.

Digital inputs

Number of inputs	10
Supply by controller	24 V DC
Supply protection	Short circuit protected to ground
Input protection	Not isolated

Analog inputs

Number of pressure inputs	2
Number of temperature inputs	5

9 Instructions for use

Air/oil separator vessel

-	This vessel can contain pressurised air; this can be potentially dangerous if the equipment is misused.
-	This vessel must only be used as a compressed air/oil separator and must be operated within the limits specified on the data plate.
-	No alterations must be made to this vessel by welding, drilling or any other mechanical methods without the written permission of the manufacturer.
-	The safety valve must correspond with pressure surges of 1.1 times the maximum allowable operating pressure. It should guarantee that the pressure will not permanently exceed the maximum allowable operating pressure of the vessel.
-	Use only oil as specified by the manufacturer.
-	This vessel has been designed and built to guarantee an operational lifetime in excess of 20 years. The vessel needs a yearly visual inspection. National legislation may require in service inspection.

10 Guidelines for inspection

Guidelines

On the Declaration of Conformity / Declaration by the Manufacturer, the harmonised and/or other standards that have been used for the design are shown and/or referred to.

The Declaration of Conformity / Declaration by the Manufacturer is part of the documentation that is supplied with this compressor.

Local legal requirements and/or use outside the limits and/or conditions as specified by the manufacturer may require other inspection periods as mentioned below.

11 Declaration of conformity

Insert logo here

EU DECLARATION OF CONFORMITY

- 1 We, (1) declare under our sole responsibility, that the product
- 2 Machine name :
- 3 Machine type :
- 4 Serial number :
- 5
- 6 Which falls under the provisions of article 12.2 of the EC Directive 2006/42/EC on the approximation of the laws of the Member States relating to machinery, is in conformity with the relevant Essential Health and Safety Requirements of this directive.

The machinery complies also with the requirements of the following directives and their amendments as indicated.

	Directive on the approximation of laws of the Member States relating to	Harmonized and/or Technical Standards used	Att'mnt
7	(2)	(3)	
8			X
9			X
10			
11			
12			X

- 13 The harmonized and the technical standards used are identified in the attachments hereafter
 - 14 <1> is authorized to compile the technical file.
 - 15
 - 16
 - 17
 - 18
 - 19
 - 20
 - 21
 - 22
 - 23
 - 24
 - 25
 - 26
 - 27
- | | | |
|-----------|--|--|
| | Conformity of the specification to the directives | Conformity of the product to the specification and by implication to the directives |
| Issued by | Engineering | Manufacturing |
| Name | | |
| Signature | | |
| Date | | |
| Place | | |

843500

Typical example of a Declaration of Conformity document

(1): Contact address:
 Atlas Copco Airpower n.v.
 P.O. Box 100
 B-2610 Wilrijk (Antwerp)
 Belgium

(2): Applicable directives

(3): Standards used

On the Declaration of Conformity / Declaration by the Manufacturer, the harmonized and/or other standards that have been used for the design are shown and/or referred to.

The Declaration of Conformity / Declaration by the Manufacturer is part of the documentation that is supplied with this device.

COMMITTED TO SUSTAINABLE PRODUCTIVITY

We stand by our responsibilities towards our customers, towards the environment and the people around us. We make performance stand the test of time. This is what we call — Sustainable Productivity.

www.atlascopco.com

